

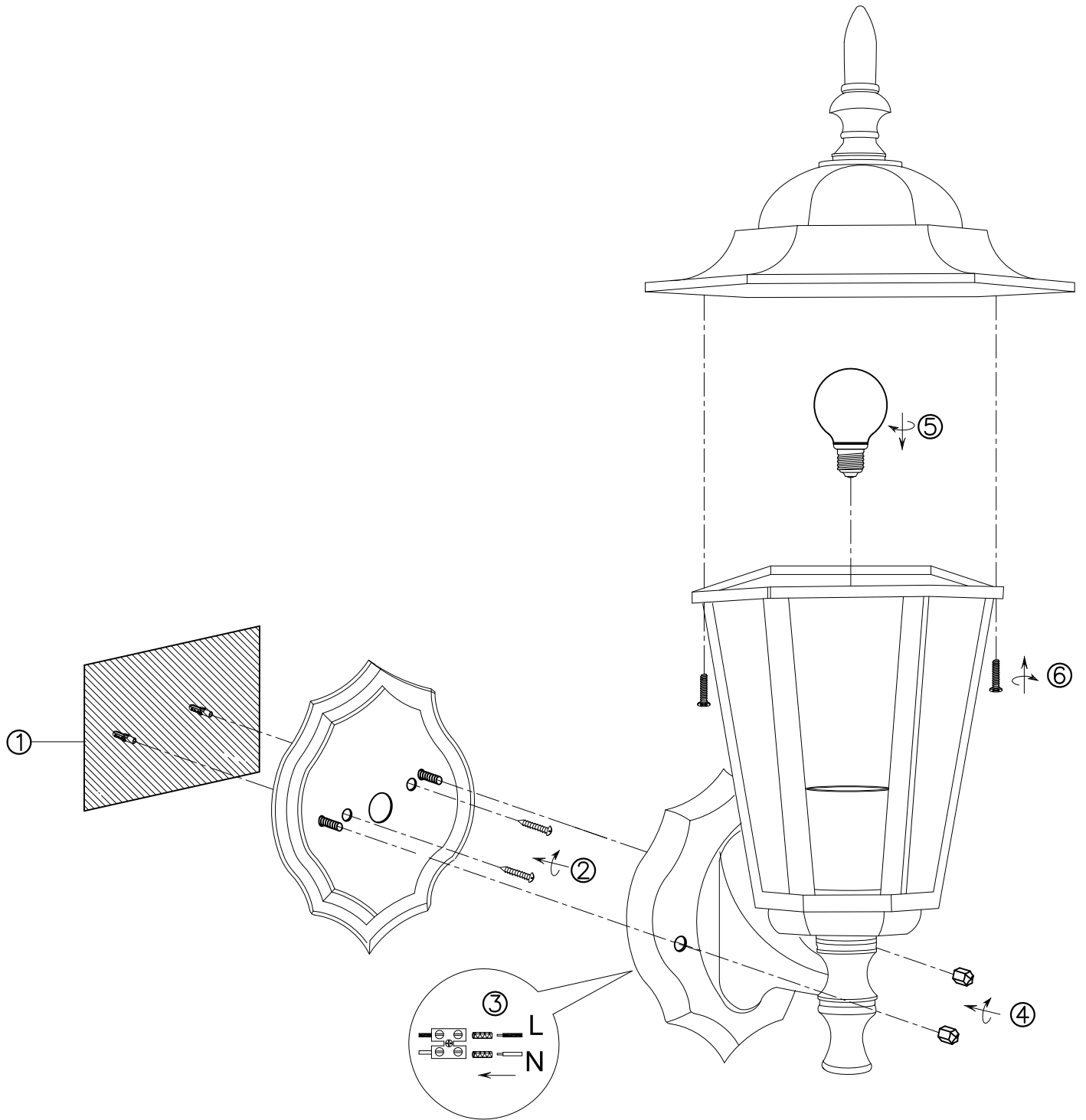



ITEM NO.:UPTON EX-BK



 Disclaimer:
 Tools not included
 Shade ring attached on lamp holder
 Globe(s) not included



Telbix.

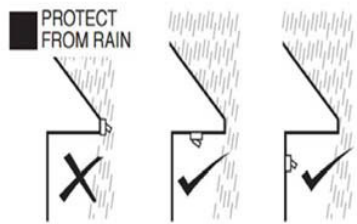

240V~50Hz E27 MAX.25W

NOTE:GLOBE NOT INCLUDED

IMPORTANT

Must be installed
by a qualified
electrical contractor.
Install in accordance
with AS/NZS3000