

## Trak-3 Track-3 Series



### Description

3 circuit track and accessories are designed for easy ceiling or wall mounting applications. Lighting tracks can be installed at any required height, and are capable of high power loads. The modular system provides the lighting designer with a flexible solution to any commercial or residential indoor lighting requirement.

### Specification Features

Input Voltage: 240V  
IP rating (IP): 20

### Diagrams / Additional

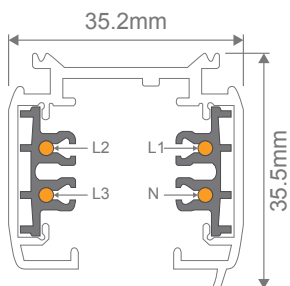

Item No.	Variant		Length
	Black	White	
Trak-3-S1M	22152	22153	1M
Trak-3-S2M	22150	22151	2M

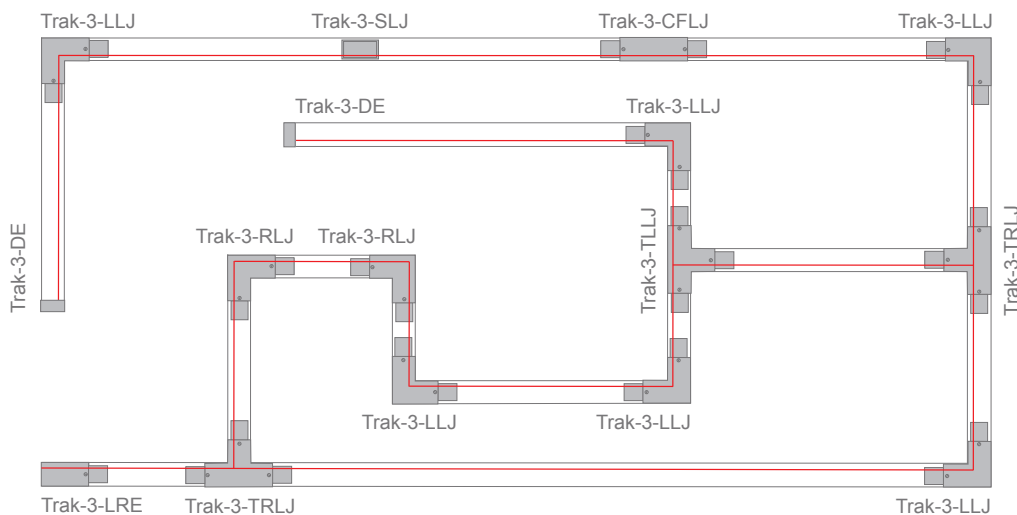

- (LRE) Live Right End
- (LLE) Live Left End
- (DE) Dead End
- (SLJ) Straight Live Joiner
- (CFLJ) Centre Feed Live Joiner
- (LLJ) L Shape Live Joiner
- (LRLJ) L Shape Live Joiner
- (SDJ) Straight Dead Joiner
- (TLLJ) T Shape Left Live Joiner
- (TRLJ) T Shape Right Live Joiner
- (ADA) Adaptor

## Trak-3 Accessories

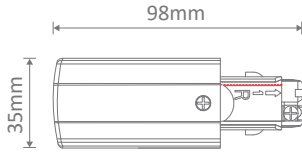

Trak-3-LRE

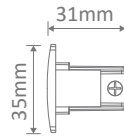

Trak-3-DE

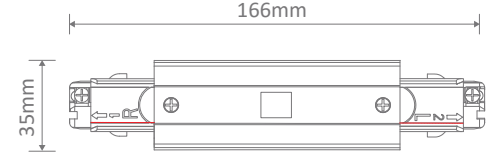

Trak-3-CFLJ

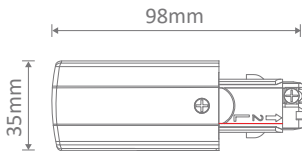

Trak-3-LLE

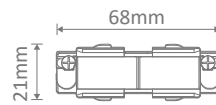

Trak-3-SLJ

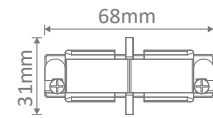

Trak-3-SDJ

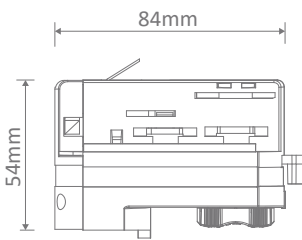

Trak-3-ADA

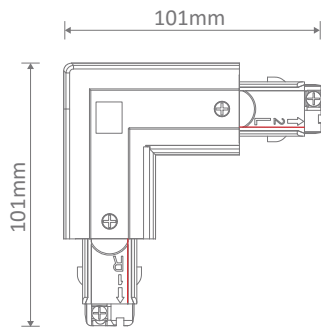

Trak-3-LLJ

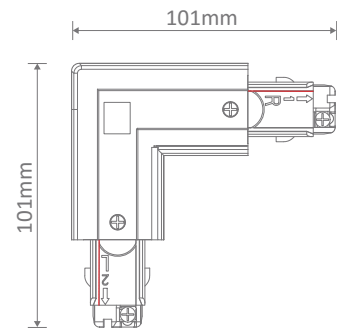

Trak-3-LRLJ

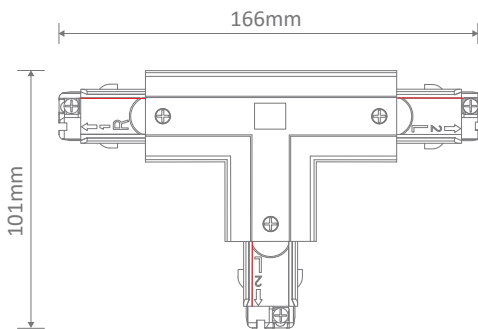

Trak-3-TRLJ

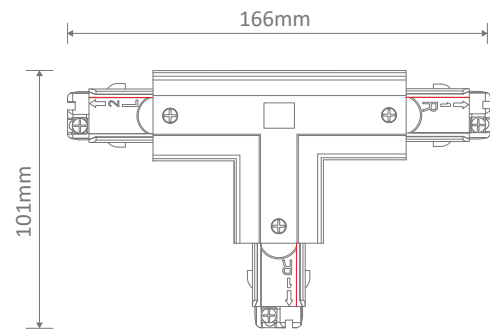

Trak-3-TLLJ

Item No.	Variant	
	Black	White
TRAK-3-LRE	22156	22157
TRAK-3-LLE	22158	22159
TRAK-3-DE	22160	22161
TRAK-3-SLJ	22162	22163
TRAK-3-LLJ	22164	22165
TRAK-3-LRLJ	22166	22167
TRAK-3-CFLJ	22188	22189

Item No.	Variant	
	Black	White
TRAK-SDJ	22170	22171
TRAK-3-TLLJ	22176	22177
TRAK-3-TRLJ	22178	22179
TRAK-3-ROD	22182	22183
TRAK-3-SUS-1.5M	22184	22185
TRAK-3-SUS-3M	22190	22191
TRAK-3-ADA	22186	22187