

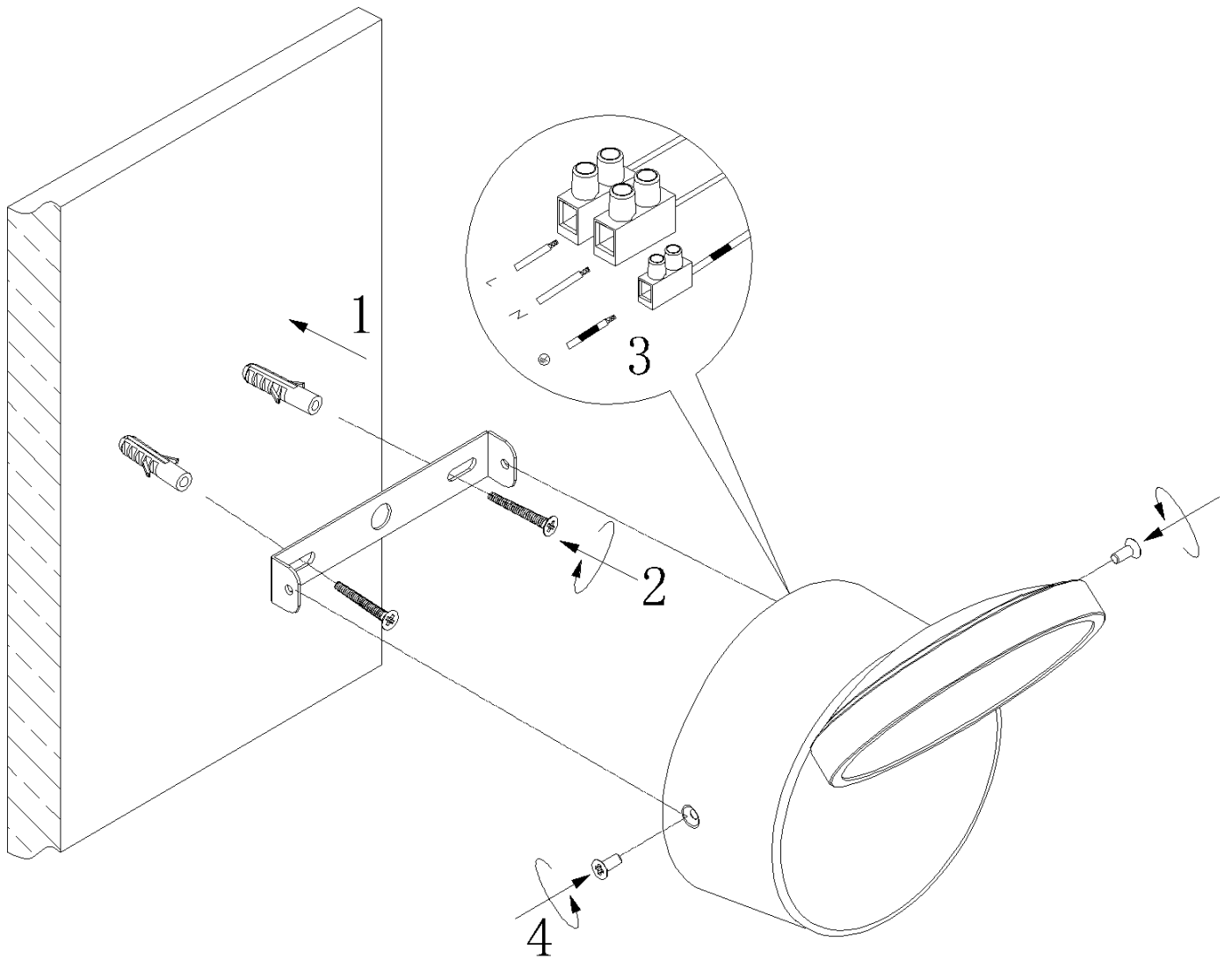



ITEM NO.: NETRA DL15



- Disclaimer:
-  Tools not included
 -  Shade ring attached on lamp holder
 -  Globe(s) not included

240V ~ 50Hz LED 15W 3000K/4000K/5000K
TRAILING EDGE DIMMER

telbix. 

IMPORTANT
Must be installed by
a qualified electrical
contractor.
Install in accordance
with AS/NZ3000