

Last modification 2024-04-10

MANDEL TL-AG 9329501072059



The Mandel Touch Lamp, complete with globe, is a sleek and innovative lighting solution that adds both style and convenience to any space. Crafted from iron and available in a variety of colours, it effortlessly merges contemporary design with practicality.

Overview

Family name	Mandel
Categories	Table Lamps
Switch	Touch
Usage	Indoor Lighting

Color / Material

Fixture Color	Antique Gold
Fixture Finish	Polished
Fixture Material	Iron
Cable Material	PVC

Size

Fixture Diameter (cm)	15.0
Fixture Height (cm)	7.5
Base Diameter (cm)	11.0
Base Height (cm)	4.0
Shade Diameter (cm)	15.0
Shade Height (cm)	7.5
Height Adjustable?	No
Cable Length (cm)	180

Specification

Voltage Input	240V
Total Wattage (max)	5
Globe Type	E14
Globe / Light Source qty	1
Globe / Light Source included	Yes
Color Temperature	Warm White

All representations within this document are subject to copyright. ELECTRICAL INSTALLATIONS MUST BE PERFORMED BY A QUALIFIED ELECTRICAL CONTRACTOR AND INSTALLED IN ACCORDANCE WITH AS/NZS 3000.
NOTE : All images , descriptions and dimensions are indicative. Please check latest version of item detail on Telbix website prior to ordering or installation.

Color Kelvin	3000k
Dimmable	No
Electrical Protection	CLASS II - DOUBLE INSULATED, EARTH NOT REQUIRED
IP rating	IP20
Lead and Plug	Yes
Approvals	RCM
Care Instructions	Do not use strong liquid cleaners, Wipe clean with a dry cloth
Replacement Warranty	*3 Years

Barcode

GTIN 9329501072059

Image -dimensions

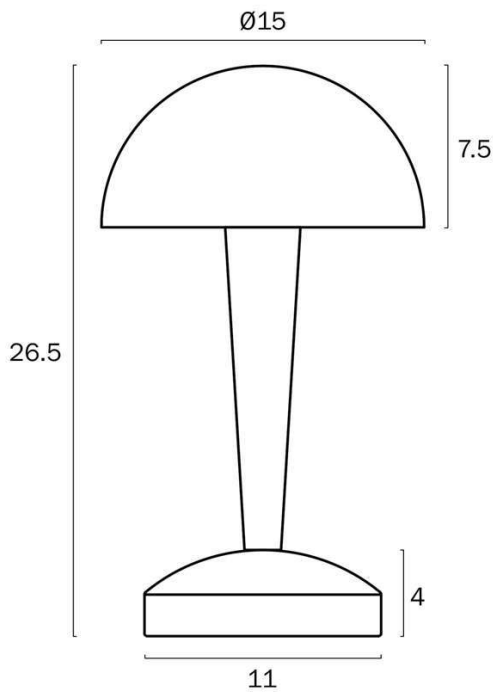

Note: Dimensions are only a guide and may vary due to manufacturing variations.

