

ITEMNO.:GOVAN PE6

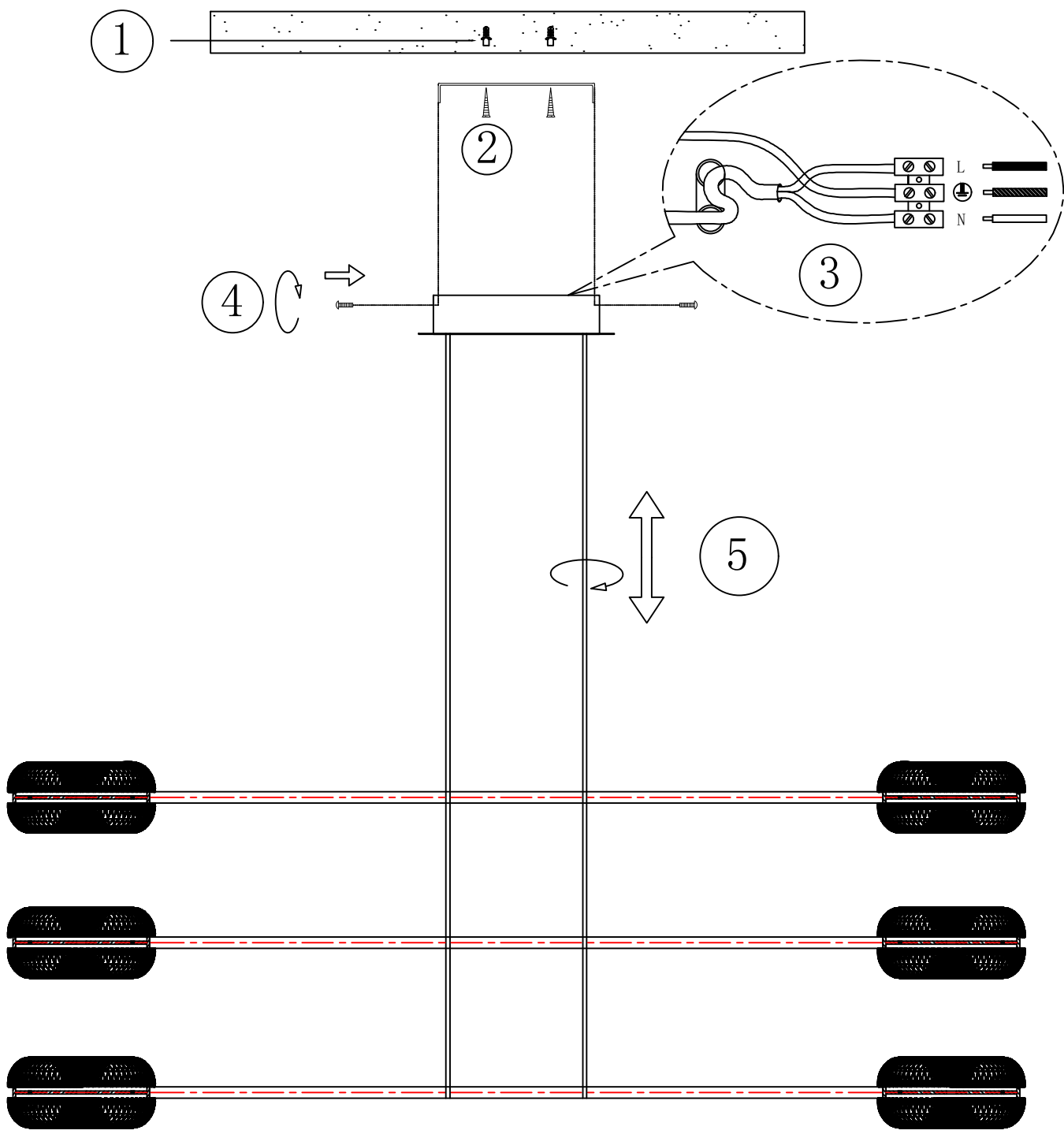

Telbix.

240V ~ 50Hz LED 10Wx6
3000K NO-DIM

IMPORTANT
Must be installed by
a qualified electrical
contractor.
Install in accordance
with AS/NZS3000