

Last modification

2023-02-01

## EARTH TL-BZWH

9329501059913



The Earth table lamp is the perfect addition to any rustic-inspired room. The lamp features a unique concentric circle pattern on the ceramic base, adding a touch of texture and dimension to your space. The fabric shade provides a warm, diffused light, making it ideal for reading or relaxing. The rustic finish of the lamp gives it a vintage, earthy feel, making it a great choice for homes with a natural aesthetic. With its sturdy ceramic base, this lamp is sure to be a durable and stylish addition to any room in your home.

### Overview

<b>Family name</b>	Earth
<b>Categories</b>	Table Lamps
<b>This item includes</b>	Shade
<b>Shade Shape</b>	Drum Tapered
<b>Switch</b>	Inline Switch
<b>Usage</b>	Indoor Lighting

### Color / Material

<b>Fixture Color</b>	Bronze,White
<b>Fixture Material</b>	Fabric,Ceramic
<b>Shade Material</b>	Fabric,Plastic
<b>Base Color</b>	Bronze,White
<b>Base Material</b>	Ceramic
<b>Cable Color</b>	Black
<b>Cable Material</b>	PVC

### Size

<b>Fixture Diameter (cm)</b>	32.0
<b>Fixture Height (cm)</b>	54.0
<b>Base Diameter (cm)</b>	17.0
<b>Base Height (cm)</b>	26.5
<b>Shade Top (cm)</b>	28.0
<b>Shade Bottom (cm)</b>	32.0
<b>Shade Height (cm)</b>	24.0
<b>Cable Length (cm)</b>	180 (30+Inline Switch+150)

## Specification

<b>Voltage Input</b>	240V
<b>Wattage (max)</b>	25
<b>Globe Type</b>	E27
<b>Globe / Light Source qty</b>	1
<b>Globe / Light Source included</b>	No
<b>Dimmable</b>	Globe Dependant
<b>Electrical Protection</b>	CLASS II - DOUBLE INSULATED, EARTH NOT REQUIRED
<b>IP rating</b>	IP20
<b>Lead and Plug</b>	Yes
<b>Approvals</b>	RCM
<b>Assembly Required</b>	Yes
<b>Box Contents</b>	Instruction
<b>Care Instructions</b>	Do not use strong liquid cleaners,Wipe clean with a dry cloth
<b>Replacement Warranty</b>	*3 Years

## Barcode

**GTIN** 9329501059913

## Image -dimensions

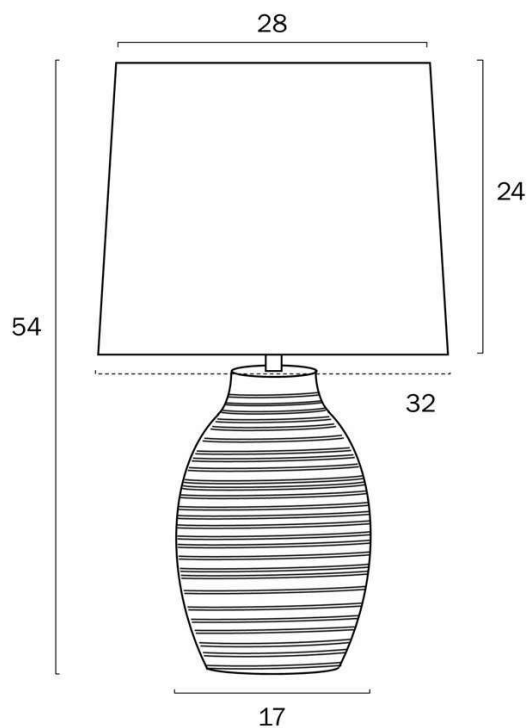

Note: Dimensions are only a guide and may vary due to manufacturing variations.



