

## MURO-PRO-30S

December 15, 2022 1:48 pm

Order Code	Product Code	Description
25062	MURO-PRO-30S-BLK-TRIO	30W Spotlight, with sensor, black finish (TRIO)
25063	MURO-PRO-30S-DGR-TRIO	30W Spotlight, with sensor, dark grey finish (TRIO)
25064	MURO-PRO-30S-WHT-TRIO	30W Spotlight, with sensor, white finish (TRIO)

Thank you for purchasing your new LED MURO-PRO-30S, Please take the time to read and understand the instruction sheet below. Failure to do so may void warranty.

### Specifications

Voltage:	240V AC, 50Hz	Lumen ( $\pm 10\%$ ):	Warm White 3000K - 1900lm Neutral White 4000K - 2100lm White 5000K - 2000lm	Dimmable:	No
Power:	30W	Beam Angle:	120°		
IP Rating:	54	CCT:	3000K - 4000K - 5000K (Switchable)		
CRI:	$\geq 80$	Lifespan:	30,000hrs		
Detection Range:	Max.12 metres at 180° scan				
Duration Time adjustment:	(10 $\pm$ 5) seconds to (4 $\pm$ 1) minutes				
Detection circuitry:	Passive Infra-Red (PIR)				

*Note: Install one fitting per switch to avoid sensor malfunction.*

The Security Light incorporates a PIR (Passive Infra Red) sensing device which continuously scans a preset operating zone and immediately switches the light on when it detects movement in that area. This means that whenever movement is detected within the range of the sensor the light will switch on automatically to illuminate pathways, steps, patios, porches, or whatever area you have selected to light for reasons of safety, convenience or security. While there is movement within range of the unit the light will remain on.

**This light is for outdoor use and only intended for normal use, must not be used for rough service (for example, on construction sites).**

*The light source of this luminaires is not replaceable; when the light source reaches its end of life the whole luminaire must be replaced*

**To achieve best results, we suggest you take into account the following points:**

- Ideally the security lamp should be mounted 1.8 to 2.5 metres (6 to 8ft) above the ground to be scanned
- To avoid damage to unit - do not aim the sensor towards the sun.
- To avoid nuisance triggering, the sensor should be directed away from heat sources such as barbecues, Air-conditioners, other outside lighting, moving cars and flue vents.
- To avoid nuisance triggering, keeping away from the area of strong electromagnetic disturbance.
- Do not aim towards reflective surfaces such as smooth white walls, swimming pools, etc. The security lamp scanning specifications (approximately 12 meters at 180°) may vary slightly depending on the mounting height and location. The detection range of the unit may also alter with temperature change. Before selecting a place to install your security lamp you should note that movement across the scan area is more effective than movement directly toward or away from the sensor. If movement is made walking directly towards or away from the sensor and not across, the apparent detection range will be substantially reduced.

**Note:** -The lamp must be installed by professional electrician  
-Ensure the power supply is switched off before fitting this product

-Do not touch the lamp when in use  
-Keep away from hot steam and corrosive gas

### Installation

1. Installation by a licensed electrician and according to IEC wiring Regulation.
2. Switch power off at the meter box and ensure that there is no power to the lamp
3. Unscrew the **Fixing Cover Screws** then remove the cover
4. Remove the **Cable Anchorage and Terminal Block**.
5. Use the plastic back box to mark the position of screw holes onto mounting surface. Drill the wall to depth of about 4 cm and fit the wall plugs (supplied). Care should be taken to avoid drilling or screwing into concealed electrical wiring.
6. Connecting the Power Cable to the **Terminal Block**, see the relative symbol in Figure, ensure the cable must drill through the **Cable Gasket**.
7. Affix the back box to the mounting surface with **Mounting Wall Screws** (supplied)
8. Re-fit the **Terminal Block and Cable Anchorage**.
9. Re-fit the cover.

### Note:

- Please power off and let the lamp cool before touching the lamp(s), because they will become hot during lighting on.
- When adjusting lamp holders, ensure that lamps are not touching or in close proximity to sensor head (more than 40mm), heat from the lamp(s) may distort the PIR Sensor or destroy the plastic encloser of PIR Sensor.
- Loosen lock nuts and screws on sensor and lamp before making any adjustments.

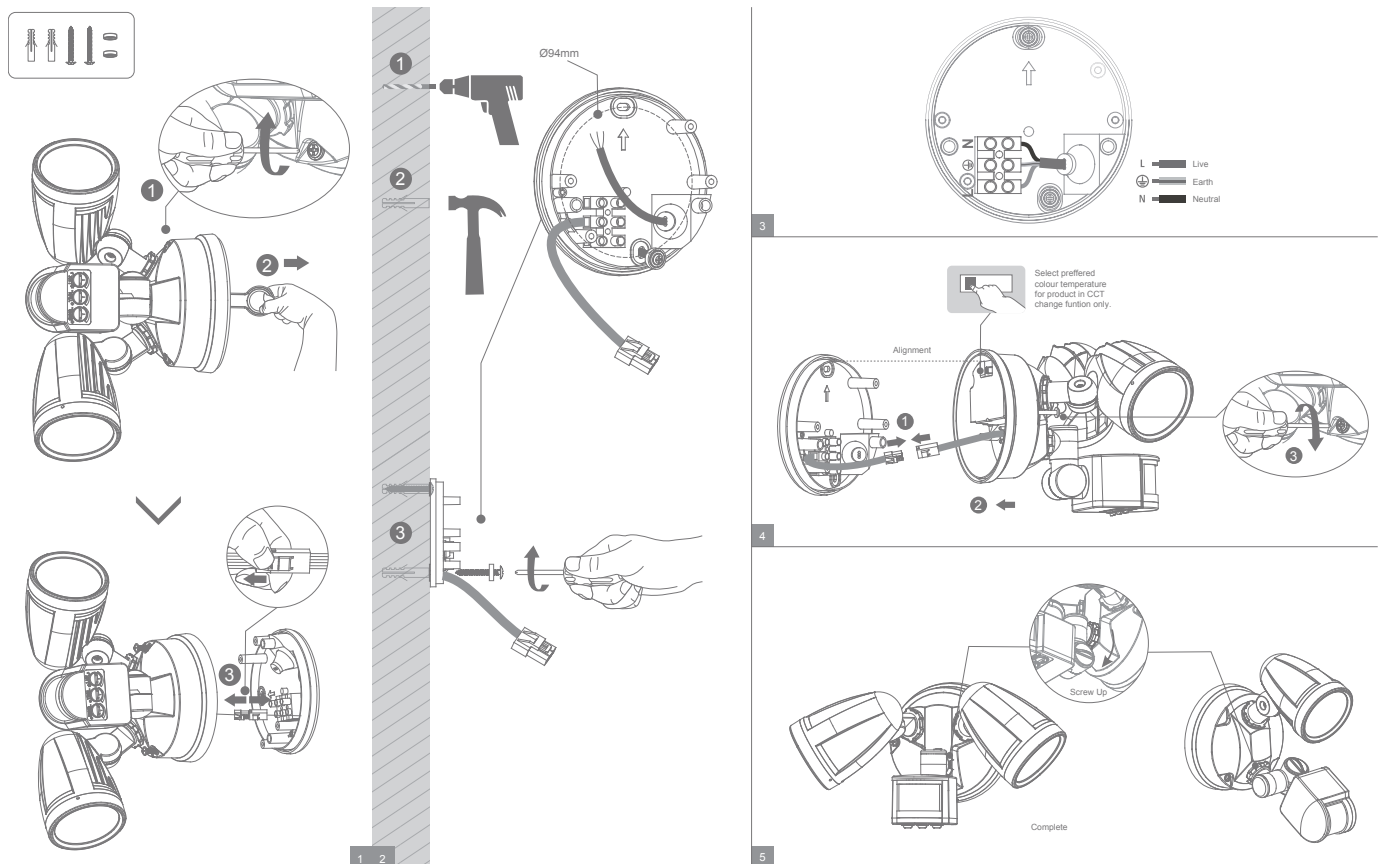

When installed under an eave it is critical that the sensor is not exposed to direct and continuous water and rain. The sensor is protected against water splashed from all directions (limited water protection permitted).

**Note:** -The lamp must be installed by professional electrician  
-Ensure the power supply is switched off before fitting this product

-Do not touch the lamp when in use  
-Keep away from hot steam and corrosive gas

### Electrician

- The security lamp should be wired to its own light switch.
- Do not interconnect with other lights on the same switch.
- Earth connection must be required.
- Multiple (More than one) Muro fittings must not be wired to a separate sensor.
- Multiple Muro Fittings cannot be wired to a single switching point.

### Understanding the controls

**Adjusting the duration time:** The length of time that remains switched on after activation can be adjusted from (10±5) seconds to (4±1) minutes. Rotating the TIME knob + to - will reduce the duration time.

**Note:** Once the light has been triggered by the PIR sensor any subsequent detection will start the timed period again from the beginning.

**Adjusting the LUX control level:** The Lux control module has a built-in sensing device (photocell) that detects daylight and darkness. The (☀) position denotes that the floodlight can work at day and night, and the (☾) position only work at night. You can set to operate the unit at the desired level by adjusting the LUX knob.

**Adjusting the sensitivity:** The sensitivity means the Maximum distance which PIR Sensor can be triggered by movement body. Turning the SENS knob + to - will decrease the sensitivity.

### Setting the controls

1. Put the Lux control knob to light (☀) position, turn the wall switch on and wait half a minute for the control circuit to stabilize. At this stage ensure that the TIME control knob is set at minimum duration. The security lamp will now switch on and remain on for about 30 seconds (within 60 seconds).
2. Direct the sensor toward the desired area to be scanned by adjusting the elbow joint and swivel joint on the sensor arm. **Important: loosen all lock nuts and screws on sensor and lamp before making any adjustments.**
3. Have another person move across the center of the area to be scanned and slowly adjust the angle of the sensor arm until the unit sensors the presence of the moving person, causing the light to switch on.
4. Adjust time control to required setting.
5. To set the light level at which the lights will automatically switch "on" at night, turn the LUX control knob from daylight to night. If the lamps are required to switch on earlier, e. g. Dusk, wait for the desired light level, then slowly turn the LUX control knob towards daylight while someone walks across the center of the area to be detected. When the floodlights switch on, release the LUX control knob. You may need to make further adjustments to achieve your ideal light level setting.

### Change the Color Temperature

1. Unscrew the **Fixing Cover Screws** then remove the cover
2. Change the Color Temperature at back of the light
3. W: 5000K
4. NW: 4000K
5. WW: 3000K
6. Re-fit the cover.
7. Mount light onto the wall

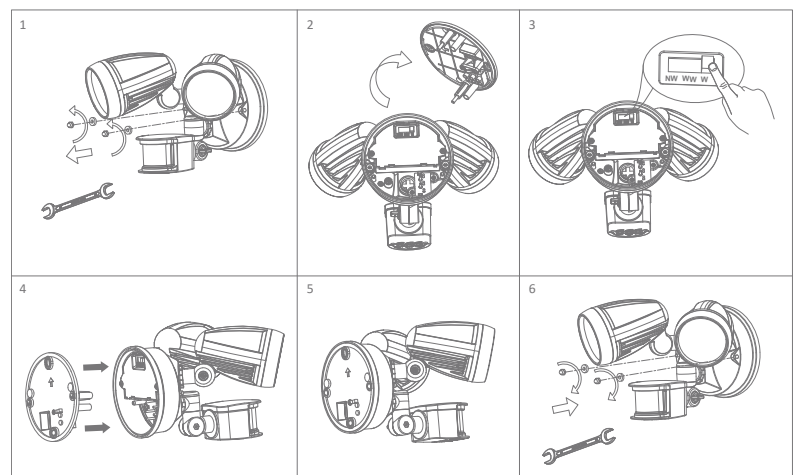

**Note:** -The lamp must be installed by professional electrician  
-Ensure the power supply is switched off before fitting this product

-Do not touch the lamp when in use  
-Keep away from hot steam and corrosive gas

## How to change into MANUAL OVERRIDE CONTROL MODE

1. Switch Main Power ON, the PIR Sensor will enter a WARM-UP Period. After 1 minute, it automatically changes into AUTO mode (leave Main switch ON and wait for lamp to switch itself OFF automatically).
2. Once the lamp is OFF, change the Main switch from the ON position to the OFF position (3) times within 3 seconds. This will change the sensor into MANUAL mode, in this mode the lamp will remain ON all the time.
3. To revert back to AUTO mode just switch the Lamp OFF, wait 8 seconds and switch it back ON.

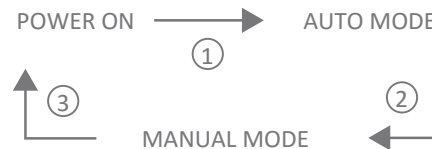

## Trouble shooting and user hints

Problem	Possible Cause	Suggested Remedy
Light does not switch on when there is movement in the detection area.	1. No mains voltage	Check all connections, and Fuses/switches
	2. Bulb(s) faulty or missing.	Check. Replace
	3. Nearby lighting is too bright.	Redirect sensor or relocate the unit
	4. Controls set incorrectly	Readjust sensor angle or control knob
	5. Sensor positioned in wrong direction	Redirect sensor and/or adjust
Lamp switches on for no apparent reason (false trigger)	1. Heat from bulb(s) activating sensor.	Adjust lamp holders to allow a Minimum gap of 40mm between LED bulb and sensor head.
	2. Heat sources such as air-con, Vents, heater flues, barbecues, other outside lighting, moving cars are activating sensor.	Adjust direction of sensor head, Away from these sources.
	3. Animals/birds e.g. possums or domestic animals.	Redirecting sensor head may help.
	4. Interference from on/off switching of electric fans or lights on the same circuit as your security floodlight. (this problem does not always occur but a faulty switch or noisy fluorescent light may cause the security lamp to switch on.)	Should the false triggering become troublesome, consider: a) Replacing a faulty switch. b) Replacing noisy fluorescent, Tubes and/or starters. c) Connecting the security lamp to a separate circuit(in most cases where one or more of the above suggestions have been carried out, false triggering has been reduced.)
	5. Reflection from swimming pool, or reflective surface.	Redirect sensor.
Light remains on.	1. Continuously false triggered	Redirecting sensor head may help
	2. Time is set too long.	Reduce time
Light switches on during daylight hours.	LUX control knob is set to daylight position.	Turn the LUX control knob to desired light level setting.
When setting controls in daylight the detection distance becomes shorter.	Interference by sunlight	Re-test at night.

*Note: all passive infra red detectors are more sensitive in cold and dry weather than warm and wet weather*