

## MURO-MAX-16S 16W LED Spotlight with Sensor



### Description

The MURO-MAX LED Security Spotlight Series provides a high brightness light output solution for outdoor lighting. Constructed from die-cast aluminium, with a glass cover, and rated at IP65, the MURO-MAX can brave the elements while providing you with a consistent wash of LED light over your favourite outdoor areas. The MURO-MAX features a fast installation backplate with male/female plug and slimline sensor, enabling detection and automatic power-up of this super bright LED spotlight. Choose from 3000K/4000K/5000K colour temperature output of the spotlight with a dip switch at the back of the fitting. Available in Black and White colour options with the choice of with or without sensor.



### Specification Features

Input Voltage:	240V
Power (W):	16W
IP rating (IP):	IP65
Lumens (lm):	Warm White 3000K - 1700lm Neutral White 4000K - 1800lm White 5000K - 1600lm
LED type:	COB
CCT:	3000K - 4000K - 5000K (Switchable)
CRI:	≥90
Beam angle (°):	100°
Dimmable:	No
Lifespan (hrs):	30,000hrs
Detection Area:	180° angle, approx 12M
Duration:	Adjustable from 10±5 sec to 4±1 min
Lux Control Level:	Adjustable from Daylight to Night
Material:	

*Note: Install one fitting per switch to avoid sensor malfunction.*

### Diagrams / Additional

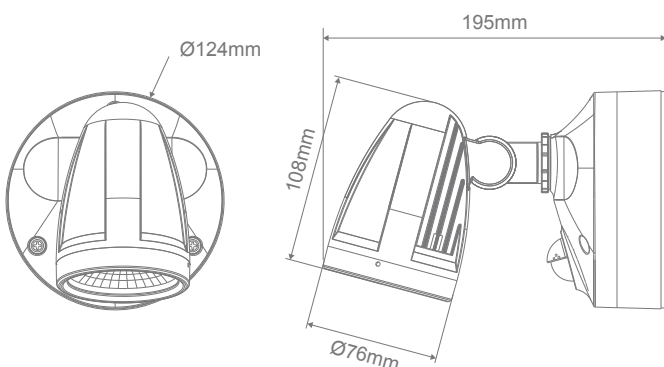

Item No.	Variant		CCT
	Wht	Blk	
MURO-MAX-16S	25083	25082	TRIO