

### MAGNETO-9

Order Code	Product Code	Description
21086	MAGNETO-9-45D-WW	9W LED Inground Light - 3000K Warm White
21088	MAGNETO-9-45D-W	9W LED Inground Light - 5000K White

Thank you for purchasing your new LED MAGNETO, Please take the time to read and understand the instruction sheet below. Failure to do so may void warranty.

### Specifications

Voltage:	24V DC**	Lumen (±5%):	Warm White 3000K - 675lm White 5000K - 720lm	Dimmable:	No
Power:	9W	Beam Angle:	45°	CRI:	≥80
IP Rating:	67	CCT:	3000K - 5000K	Lifespan:	40,000hrs
Drive Over:	2000Kg	Impact Rating:	IK90		

\*\*24V DC Constant Voltage LED Driver required - Wire in Parallel

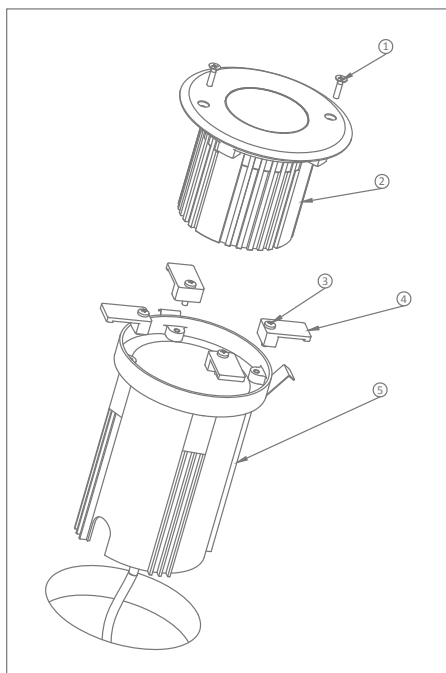

1. Drill a hole with the diameter of  $\varnothing 115$  in the ground.

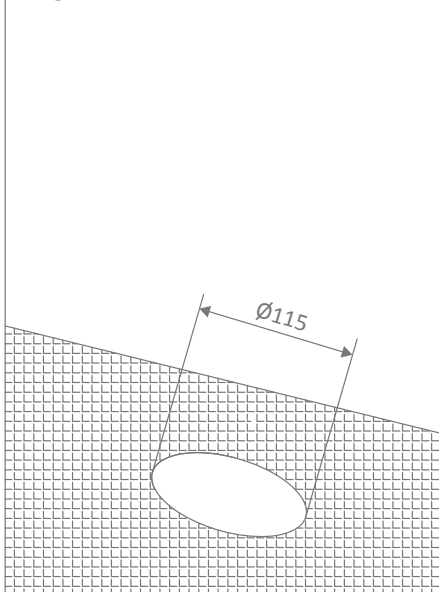

2. Connect the housing (5) to main power cord and insert housing into the hole.  
"Note: Orange holders (4) must be parallel to the ground, to guarantee alignment, the use of silicon is required around the housing (5) to hold it in position"

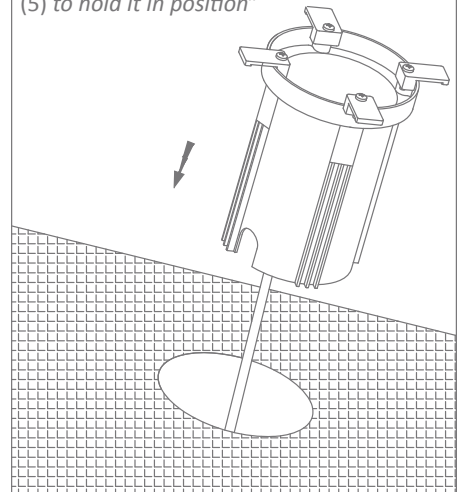

3. Once silicon has cured, remove screws (3) and orange holders (4) from the housing (5).

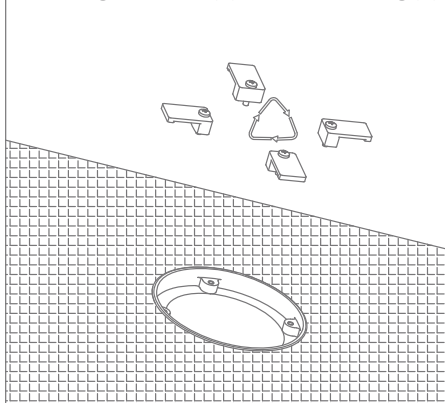

4. Insert the luminaire (2) into the housing (5). Fasten luminaire (2) to housing (5), using the screws (1) provided.

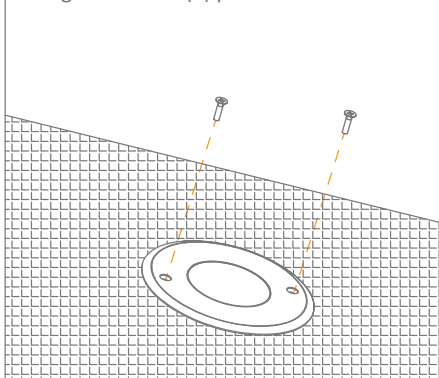

**Note:** -The lamp must be installed by professional electrician  
-Ensure the power supply is switched off before fitting this product

-Do not touch the lamp when in use  
-Keep away from hot steam and corrosive gas