

MAGNETO-3

Date: 09/2018

Order Code	Product Code	Description
21080	MAGNETO-3-25D-WW	3W Spot LED Inground Light - 3000K Warm White
21081	MAGNETO-3-25D-W	3W Spot LED Inground Light - 5000K White
21082	MAGNETO-3-60D-WW	3W Flood LED Inground Light - 3000K Warm White
21083	MAGNETO-3-60D-W	3W Flood LED Inground Light - 5000K White

Thank you for purchasing your new LED MAGNETO, Please take the time to read and understand the instruction sheet below. Failure to do so may void warranty.

Specifications

Voltage:	24V DC**	Lumen (±5%):	Warm White 3000K - 95lm White 5000K - 95lm	Dimmable:	No
Power:	3W	Beam Angle:	25° & 60°	CRI:	≥80
IP Rating:	67	CCT:	3000K - 5000K	Lifespan:	40,000hrs
Drive Over:	2000Kg	Impact Rating:	IK90		

**24V DC Constant Voltage LED Driver required - Wire in Parallel

1. Pre-drill a hole following measurements as per illustration below.
2. Connect Induction housing to main power ensuring the connection is waterproof.
3. Insert the luminaire into the induction housing and screw with fixings provided.

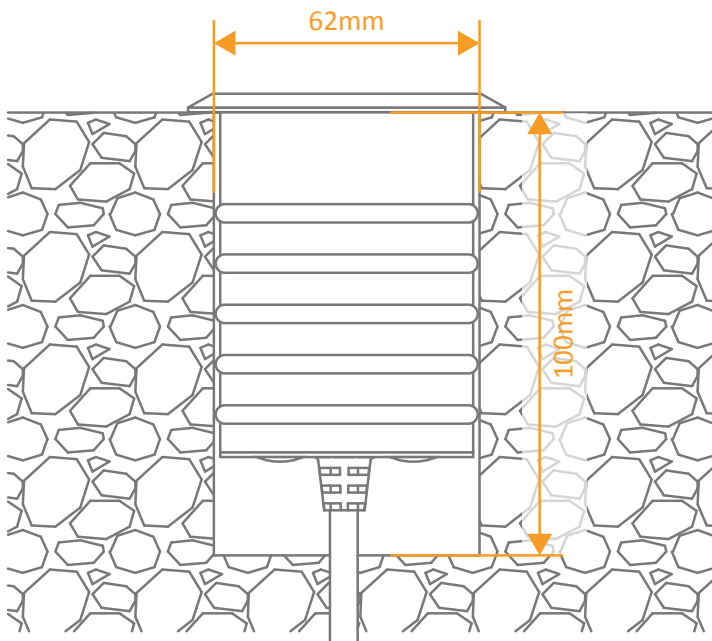

Cutout: Ø60-65mm

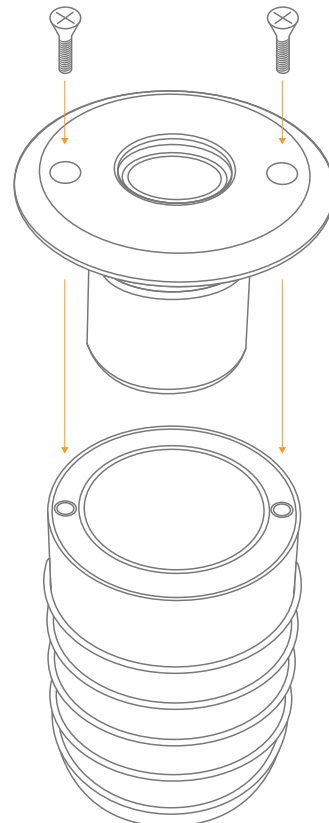

Note: -The lamp must be installed by professional electrician
-Ensure the power supply is switched off before fitting this product

-Do not touch the lamp when in use
-Keep away from hot steam and corrosive gas