

### MAGNETO-18

| Order Code | Product Code      | Description  |
|------------|-------------------|--|
| 21095      | MAGNETO-18-45D-WW | 18W Flood LED Inground Light - 3000K Warm White    |
| 21096      | MAGNETO-18-45D-NW | 18W Flood LED Inground Light - 4000K Neutral White |
| 21098      | MAGNETO-18-45D-W  | 18W Flood LED Inground Light - 5000K White         |

Thank you for purchasing your new LED MAGNETO, Please take the time to read and understand the instruction sheet below. Failure to do so may void warranty.

### Specifications

|             |          |                |   |           |           |
|-------------|----------|----------------|---|-----------|-----------|
| Voltage:    | 24V DC** | Lumen (±5%):   | Warm White 3000K - 1350lm<br>Neutral White 4000K - 1400lm<br>White 5000K - 1450lm | Dimmable: | No        |
| Power:      | 18W      | Beam Angle:    | 45°   | CRI:      | ≥80       |
| IP Rating:  | IP67     | CCT:           | 3000K - 4000K - 5000K   | Lifespan: | 40,000hrs |
| Drive Over: | 2000Kg   | Impact Rating: | IK90  |           |           |

\*\*24V DC Constant Voltage LED Driver required - Wire in Parallel

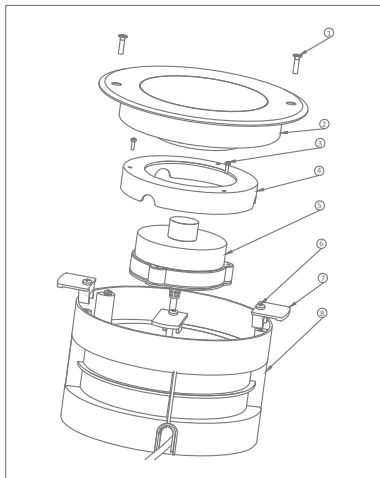

1. Drill a hole of Ø206mm in the ground, insert housing (8) "Note: Orange holders (7) must be parallel to the ground, to guarantee alignment, the use of silicon is required around the housing (8) to hold it in position"

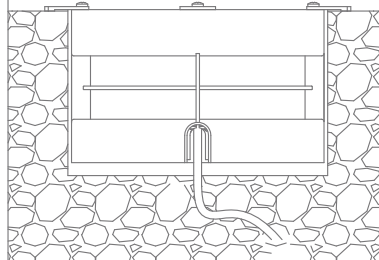

2. Once silicon has cured, remove screws (6) and orange holders (7) from the housing (8).

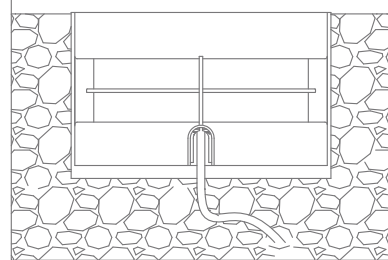

3. Connect induction module (5) to the power source and insert into housing (8). Fix into place by screwing the outer rim (4) over the induction module (5), by using the screws (3) provided.

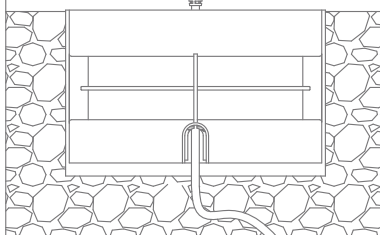
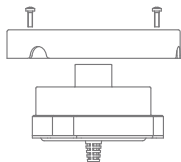

4. Insert the luminaire (2) into the housing (8).

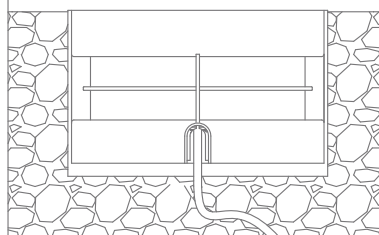
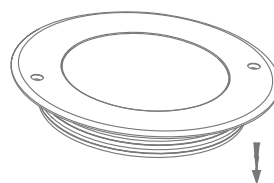

5. Fasten luminaire (2) to housing (8), using the screws (1) provided.

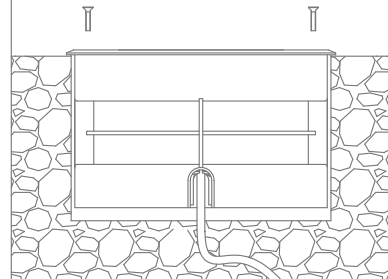

**Note:** -The lamp must be installed by professional electrician  
-Ensure the power supply is switched off before fitting this product

-Do not touch the lamp when in use  
-Keep away from hot steam and corrosive gas