

Last modification

2023-11-15

LARSON TL-WH

9329501067666



Discover the essence of Nordic chic with the Larson lamp—a sleek embodiment of Scandinavian style. Its gracefully curved arm supports a double-layered conical shade, creating a harmonious design that emanates warmth. Ideal for a G9 LED light source, this lamp is offered in three unique color combinations. Choose between table and floor variations to effortlessly integrate Larson's timeless and minimalist charm into your space.

Overview

Family name	Larson
Categories	Table Lamps
Switch	Inline Switch
Usage	Indoor Lighting

Color / Material

Fixture Color	White
Fixture Finish	Matte
Fixture Material	Iron

Size

Fixture Length (cm)	28.0
Fixture Width (cm)	20.0
Fixture Height (cm)	43.0
Base Diameter (cm)	18.0
Base Height (cm)	3.0
Shade Diameter (cm)	20.0

Specification

Voltage Input	240V
Total Wattage (max)	6
Globe Type	G9
Globe / Light Source qty	1
Globe / Light Source included	No
Electrical Protection	CLASS II - DOUBLE INSULATED, EARTH NOT REQUIRED
IP rating	IP20

All representations within this document are subject to copyright. ELECTRICAL INSTALLATIONS MUST BE PERFORMED BY A QUALIFIED ELECTRICAL CONTRACTOR AND INSTALLED IN ACCORDANCE WITH AS/NZS 3000.
NOTE : All images , descriptions and dimensions are indicative. Please check latest version of item detail on Telbix website prior to ordering or installation.

Lead and Plug	Yes
Approvals	RCM
Box Contents	Instruction
Care Instructions	Do not use strong liquid cleaners, Wipe clean with a dry cloth
Replacement Warranty	*3 Years

Barcode

GTIN 9329501067666

Image -dimensions

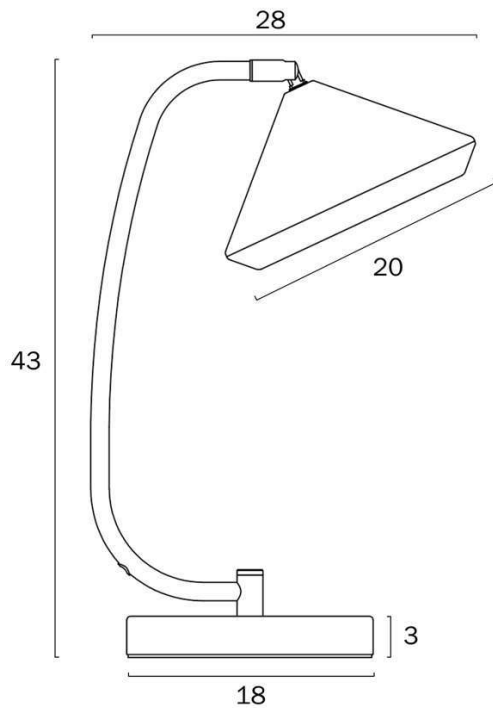

Note: Dimensions are only a guide and may vary due to manufacturing variations.

