

Last modification

2023-11-15

## LARSON TL-BK 9329501067659



Discover the essence of Nordic chic with the Larson lamp—a sleek embodiment of Scandinavian style. Its gracefully curved arm supports a double-layered conical shade, creating a harmonious design that emanates warmth. Ideal for a G9 LED light source, this lamp is offered in three unique color combinations. Choose between table and floor variations to effortlessly integrate Larson's timeless and minimalist charm into your space.

### Overview

<b>Family name</b>	Larson
<b>Categories</b>	Table Lamps
<b>Switch</b>	Inline Switch
<b>Usage</b>	Indoor Lighting

### Color / Material

<b>Fixture Color</b>	Black
<b>Fixture Finish</b>	Matte
<b>Fixture Material</b>	Iron

### Size

<b>Fixture Length (cm)</b>	28.0
<b>Fixture Width (cm)</b>	20.0
<b>Fixture Height (cm)</b>	43.0
<b>Base Diameter (cm)</b>	18.0
<b>Base Height (cm)</b>	3.0
<b>Shade Diameter (cm)</b>	20.0

### Specification

<b>Voltage Input</b>	240V
<b>Total Wattage (max)</b>	6
<b>Globe Type</b>	G9
<b>Globe / Light Source qty</b>	1
<b>Globe / Light Source included</b>	No
<b>Electrical Protection</b>	CLASS II - DOUBLE INSULATED, EARTH NOT REQUIRED
<b>Lead and Plug</b>	Yes

All representations within this document are subject to copyright. ELECTRICAL INSTALLATIONS MUST BE PERFORMED BY A QUALIFIED ELECTRICAL CONTRACTOR AND INSTALLED IN ACCORDANCE WITH AS/NZS 3000.  
NOTE : All images , descriptions and dimensions are indicative. Please check latest version of item detail on Telbix website prior to ordering or installation.

**Replacement Warranty** \*3 Years

Barcode

**GTIN** 9329501067659

Image -dimensions

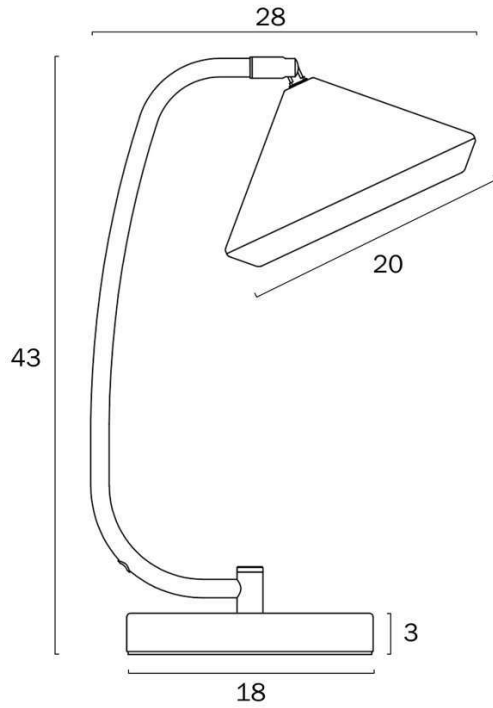

Note: Dimensions are only a guide and may vary due to manufacturing variations.

