

## Product Specifications

Model No.	HV6092T	HV6094T
Name	Orah	Orah
Material	Walnut Timber + Aluminium	Walnut Timber + Aluminium
Colour	Walnut + Black	Walnut + Black
Installation Type	Ceiling - Suspended	Ceiling - Suspended
Cable Length	3000mm Adjustable	3000mm Adjustable
IP Rating	IP20	IP20
Input Voltage	240v	240v
Protection Class	1 (Requires Earth)	1 (Requires Earth)
Lamp Base	Built in LED	Built in LED
Lamp Wattage	1x 40w	1x 60w
Colour Temp	TRI-Colour - 3000k, 4000k, 5500k	TRI-Colour - 3000k, 4000k, 5500k
Lumens	3200lm, 3300lm, 3400lm	4800lm, 5000lm, 4900lm
CRI	> 80	> 80
Wiring	Parallel	Parallel
Dimmable	Yes - Triac Dimmable	Yes - Triac Dimmable
Warranty	3 Years Replacement*	3 Years Replacement*

### HV6092T Dimensions

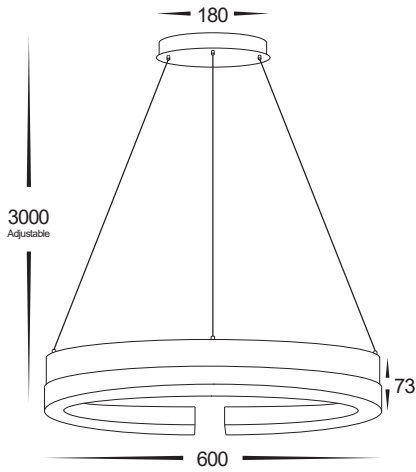

### HV6094T Dimensions

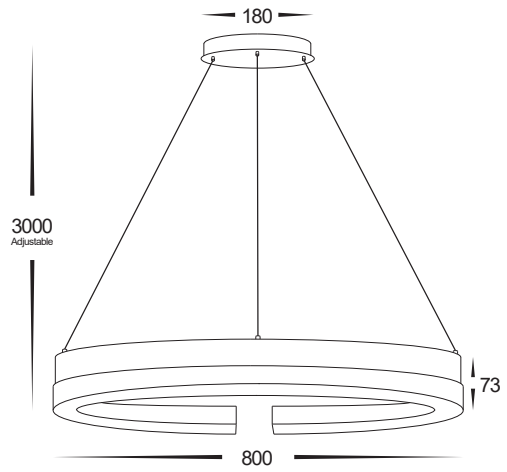

### Important Safety Issues:

- This product must be installed by a qualified electrician according to AS/NZS 3000.
- Ensure all electrical mains are disconnected before any installation.
- Modification of this product will void any warranty.
- Havit Lighting does not take responsibility for wrong installation, incorrect use, or use of installation material that does not belong to the system.
- Aluminium and 304SS fittings must not be installed within 5km of any salt water environments.
- All o-rings and seals must be in place correctly to maintain warranty
- This form may be updated at any time due to product improvements, please check online installation form for most current version.

### Steps for Installation:

1. Make sure that the electrical circuit is free of voltage (master switch off)
2. Remove bracket from canopy by removing screws from side and set aside.
3. Install Bracket in desired location using appropriate screws for application
4. Adjust cable length and cut off any excess.
5. Connect the cable: Use wire with earth, connect earth first then positive and then neutral
6. Fitting is preset to 3000k, To change slide switch located in canopy of fitting to desired colour temperature
7. Reattach canopy to bracket by pushing up gently into place.
8. Reattach screws on to side of canopy making sure these are tight.
9. All connections must be carried out carefully, inspect all contacts before switching back on the electric circuit.

**Must be installed by a licensed electrician**

### Contact Details:

143 Beauchamp Road  
Matraville NSW 2036  
Australia

Tel: 02 9381 8300  
Fax: 02 9666 8881  
Email: sales@havit.com.au  
Web: www.havit.com.au

### Warranty Terms & Conditions\*



[www.havit.com.au](http://www.havit.com.au)

