

Lumo Wall Light Installation Instructions



Product Specifications

Model No.	HV3694W-BLK
Name	Lumo
Material	Aluminium Body + Glass Cover
Colour	Black
IP Rating	IP54
Installation Type	Wall - Surface Mounted
Protection Class	1 (240v Requires Earth) ⚡
Input Voltage	240v AC
Lamp Base	E27
Lamp Wattage	1x 9w
Colour Temp	2700k
Lumens	700lm
CRI	> 80
Dimmable	Yes - Triac
Warranty	3 Years Replacement*

Important Safety Issues:

- This product must be installed by a qualified electrician according to AS/NZS 3000.
- Ensure all electrical mains are disconnected before any installation.
- Modification of this product will void any warranty.
- Havit Lighting does not take responsibility for wrong installation, incorrect use, or use of installation material that does not belong to the system.
- Aluminium and 304SS fittings must not be installed within 5km of any salt water environments.
- All o-rings and seals must be in place correctly to maintain warranty
- This form may be updated at any time due to product improvements, please check online installation form for most current version.

Dimensions

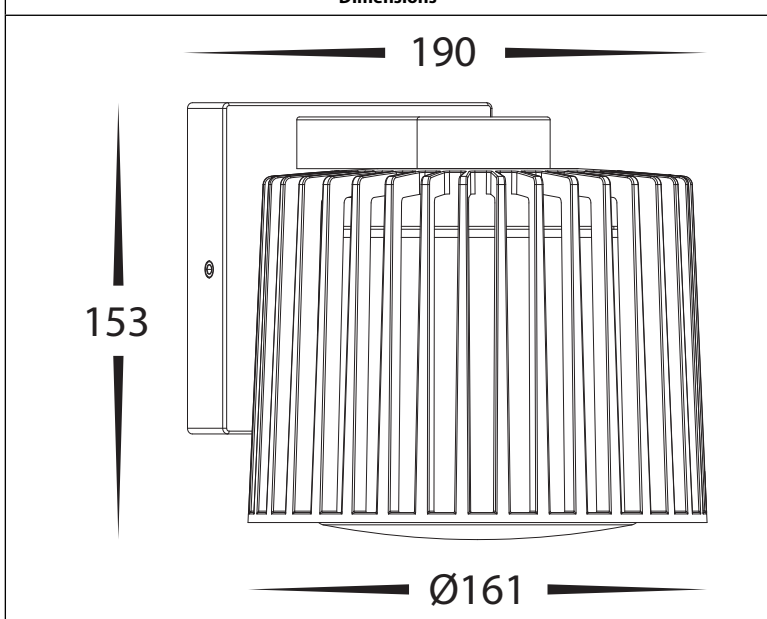

Mounting Base Dimensions

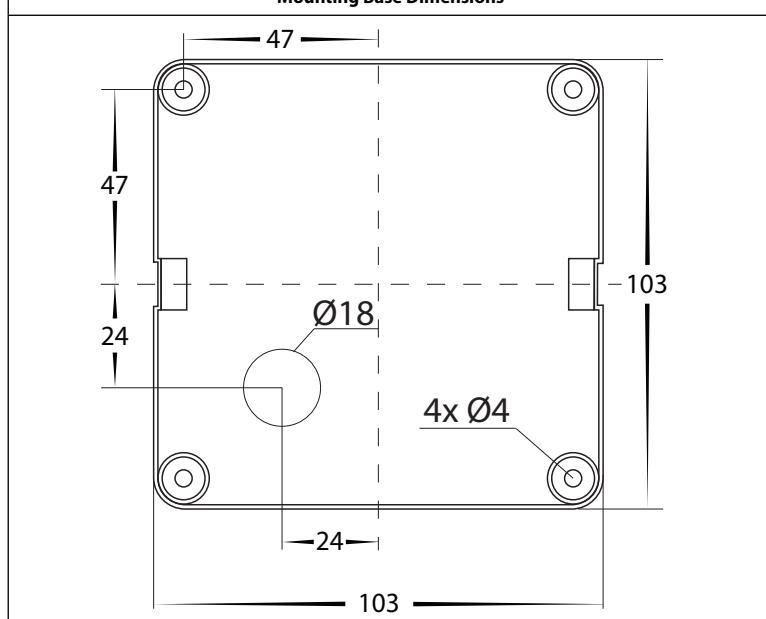

Steps for Installation:

1. Make sure that the electrical circuit is free of voltage (master switch off)
2. Remove screws from side of fitting and set aside.
3. Remove base plate from fitting.
4. Slide cable through cable gland and place base plate against wall
5. Attach base plate to wall using appropriate screws for application.
6. Seal all holes including cable entry and around screws.
7. Connect the cable - use wire with earth; connect the earth first, then live and neutral wire.
8. Reattach fitting to base plate making sure seals are still in place
9. Reinsert screws into side of fitting and tighten making sure these are tight enough to avoid any water penetration.
10. Apply silicon around edge of base to prevent any water from getting inside to electrical connections.
11. All connections must be carried out carefully, inspect all contacts before switching back on the electric circuit.

Steps for Changing globe:

1. Make sure that the electrical circuit is free of voltage (master switch off).
2. Remove cover from fitting by twisting anti clockwise and set aside.
3. Remove globe by twisting anti clockwise
4. Re-insert the appropriate globe by twisting clockwise into the lamp holder (Make sure not to exceed max wattage, see product label for correct info)
5. Reattach cover by turning clockwise making sure the seals are still in place and cover is tight to avoid any water penetration.

Must be installed by a licensed electrician

Contact Details:

143 Beauchamp Road
Matraville NSW 2036
Australia

Tel: 02 9381 8300
Fax: 02 9666 8881
Email: sales@havit.com.au
Web: www.havit.com.au

Warranty Terms & Conditions*



www.havit.com.au

