

Ashton Wall Light Installation Instructions



Product Specifications

Model No.	HV3537W-S-BLK
Name	Ashton
Material	Galvanised Iron
Colour	Black
IP Rating	IP44
Installation Type	Wall - Surface Mounted
Protection Class	1 (240v Requires Earth) ⚡
Input Voltage	240v AC
Lamp Base	E27
Lamp Wattage	1x 4w
Colour Temp	2700k
Lumens	300lm
CRI	> 80
Wiring	Parallel
Dimmable	Yes - Triac Dimmable
Warranty	3 Years Replacement*

Dimensions

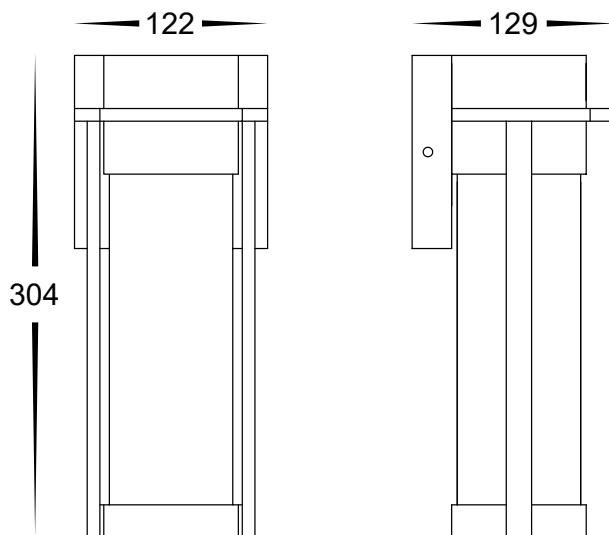

Important Safety Issues:

- This product must be installed by a qualified electrician according to AS/NZS 3000.
- Ensure all electrical mains are disconnected before any installation.
- Modification of this product will void any warranty.
- Havit Lighting does not take responsibility for wrong installation, incorrect use, or use of installation material that does not belong to the system.
- All 316 stainless steel fittings must have regular cleaning maintenance to avoid any tea staining from forming on fitting. (Warranty does not cover Tea Staining).
- All o-rings and seals must be in place correctly to maintain warranty
- Rubber Pads must be used to avoid any damage to glass.
- Care must be taken when installing glass to avoid any breakages
- This form may be updated at any time due to product improvements, please check online installation form for most current version.

Assembly Instructions

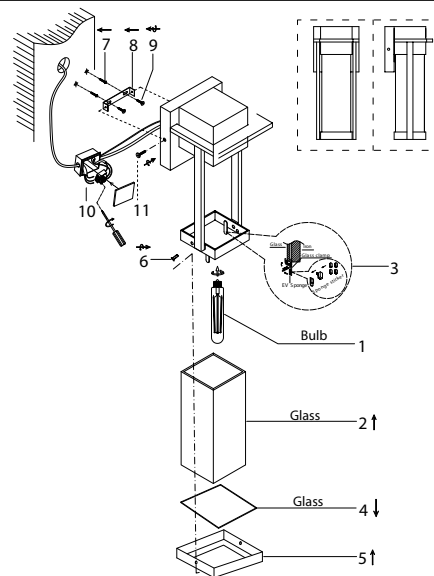

Steps for Installation:

1. Make sure that the electrical circuit is free of voltage (master switch off)
2. Apply Rubber pads to all Tabs on fitting before installing any glass
3. Remove bottom cover of fitting by removing screws on side and set aside
4. Bend tabs near lampholder to allow for holding of glass
5. Insert Globe into fitting by inserting into lamp holder and twist clockwise
6. Insert large glass into fitting and bend tabs to hold into place
7. Insert glass into bottom cover and bend tabs to hold into place
8. Reattach Bottom cover to fitting and tighten screws
9. Remove bracket from fitting by removing screws on side of fitting and set aside.
10. Install bracket to wall in desired location using appropriate screws for application.
11. Undo screws on junction box at back of fitting and set aside cover
12. Connect the cable - use wire with earth; connect the earth first, then live and neutral wire.
13. Reattach cover to junction box making sure seals are still in place and tighten screws
14. Attach fitting to bracket and tighten screws making sure they are tight.
15. Apply silicon around edge of fitting to prevent any water from getting inside to electrical connections.
16. All connections must be carried out carefully, inspect all contacts before switching back on the electric circuit.

Steps for changing globe:

1. Make sure that the electrical circuit is free of voltage (master switch off)
2. Remove bottom cover by removing screws on side of fitting.
3. Remove globe by twisting anti clockwise.
4. Reattach Cover by tightening screws.
5. Re-insert the appropriate globe by inserting globe into lamp holder and twist clockwise - (Make sure not to exceed max wattage, see product label for correct info).

Must be installed by a licensed electrician

Contact Details:

143 Beauchamp Road
Matraville NSW 2036
Australia

Tel: 02 9381 8300
Fax: 02 9666 8881
Email: sales@havit.com.au
Web: www.havit.com.au

Warranty Terms & Conditions*



www.havit.com.au

