

Sako Recessed Step Light Installation Instructions



Product Specifications

Model No.	HV3263T
Name	Sako
Material	316 Stainless Steel
Colour	Stainless Steel
Cut out Out Without Canister	Ø60
IP Rating	IP65
IK Rating	IK10
Installation Type	Wall - Recessed
Input Voltage	12v DC - Constant Voltage
Protection Class	3 (Low Voltage - no earth required) ⚡
Lamp Base	Built in LED
Lamp Wattage	1x 1.5w
Colour Temp	3000k, 4000k, 5500k
Lumens	100lm, 110lm, 105lm
CRI	> 80
Wiring	Parallel
Dimmable	Yes
Warranty	3 Years Replacement*

Important Safety Issues:

- This product must be installed by a qualified electrician according to AS/NZS 3000.
- Ensure all electrical mains are disconnected before any installation.
- Modification of this product will void any warranty.
- Havit Lighting does not take responsibility for wrong installation, incorrect use, or use of installation material that does not belong to the system.
- When installing low voltage fittings, Voltage to fitting must be within +or- 5% of voltage required and cannot be installed more than 25m from LED Driver, if not within this allowance warranty will be voided.
- When installing brass fittings, gloves must be worn to avoid any oils transferring to fitting.
- All 316 stainless steel fittings must have regular cleaning maintenance to avoid any tea staining from forming on fitting. (Warranty does not cover Tea Staining)
- All o-rings and seals must be in place correctly to maintain warranty.
- These instructions may be updated at any time due to product improvements, Please visit website for most current installation instructions.

Dimensions

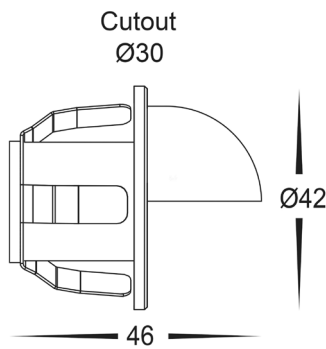

Sample Wiring Diagram

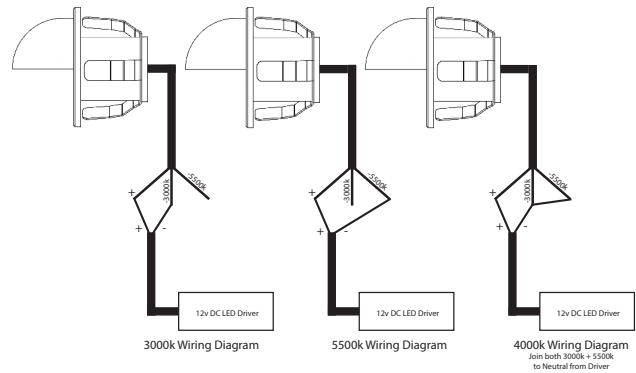

Steps for Installation:

1. Make sure that the electrical circuit is free of voltage (master switch off)
2. If installing into concrete or brick make a hole using dimensions on line drawings and table,
3. If installing into Gyprock, make a hole where fitting is to be placed using dimensions provided on line drawings and in table,
4. Using an appropriate 12v DC Constant Voltage LED Driver - DO NOT CONNECT LIGHT FITTING DIRECTLY TO 240V
5. Connect the cable - If more than one fitting installed, wiring must be done in parallel.
6. Strip back the cable on both fitting and cable run and twist the positive cables together.
7. Neutral cables are marked for selection of colour temperature. If 3000k or 5500k is selected you must terminate extra cable to be IP Rated to avoid any water making contact with internal parts of cable. To get 4000k , Join both 3000k + 5500k together and connect to neutral on cable run.
8. Solder all joins using solder and either a heat gun or butane gas torch.
9. Cover connections using an adhesive lined heat shrink or gel cap to make connection watertight. Failure to do this will void warranty.
10. Heat the heat shrink or crimp the gel cap making sure all connections are covered.
11. Apply pressure on spring clips and insert in either canister (Not Supplied) or gyprock wall and release allowing spring clips to hold fitting in place.
12. If installed outdoors apply silicon around edge of fitting to prevent any water from getting inside to electrical connections.
13. All connections must be carried out carefully, inspect all contacts before switching back on the electric circuit.

Must be installed by a licensed electrician

Contact Details:

143 Beauchamp Road
Matraville NSW 2036
Australia
Tel: 02 9381 8300
Fax: 02 9666 8881
Email: sales@havit.com.au
Web: www.havit.com.au

Warranty Terms & Conditions*



www.havit.com.au

