

DUGO SERIES · EXTERIOR UP & DOWN WALL LIGHT

HV10293T + HV10393T

Aluminium Black or White Up & Down Wall Light



HV10293T

HV10393T

NAME	Dugo
DIMENSIONS	Ø40 × 280 mm
INSTALLATION TYPE	Wall - Surface Mounted
INPUT VOLTAGE	240V AC · 50Hz
PROTECTION CLASS	1 - Earth Required
LED	2 × 3W · Built-in
COLOUR TEMP.	TRI Colour · 3000 / 4000 / 5500K
IP RATING	IP65
BODY	Powder-Coated Aluminium
DIMMABLE	No
WARRANTY	3 Years Replacement

! IMPORTANT — READ BEFORE INSTALLATION

This is a 240V mains-voltage fitting. In Australia and New Zealand, fixed mains wiring must be carried out by a licensed electrician in accordance with AS/NZS 3000 (Wiring Rules). Do not attempt to wire or connect this product yourself.

1 Important Safety Issues

- Installation must be carried out by a licensed electrician in accordance with AS/NZS 3000 wiring rules.
- Ensure mains power is disconnected before installation.
- Do not modify the fitting in any way, as this will void warranty.
- Ensure all seals, gaskets, and cable entries are correctly installed to maintain IP rating.
- Aluminium fittings should not be installed within 5km of saltwater environments.
- Failure to correctly seal the fitting may allow water ingress and void warranty.
- Before drilling, cutting, or installing, ensure there are no concealed electrical cables, water pipes, or gas lines behind the mounting surface.
- Do not install the fitting on surfaces subject to excessive vibration or movement.
- The fitting must not be covered with insulation material or combustible materials.
- Do not install near heat sources, gas appliances, or areas with excessive ambient temperatures.
- Ensure the mains supply voltage matches the product rating of 240V AC.
- Disconnect power immediately if the fitting becomes damaged, cracked, or exposed to moisture internally.
- Do not attempt to replace the built-in LED module, as it is non-serviceable.
- This product contains electronic components that must not be disposed of with general household waste.
- Maintain all IP65 seals and gaskets during installation to prevent water ingress.
- Suitable for wall mounting only. Do not install in-ground, underwater, or fully submerged applications.
- Avoid direct high-pressure water exposure from pressure washers or irrigation systems.
- Ensure drainage is maintained and the fitting is not installed in locations where water can pool around cable entries.
- Do not energise the fitting while partially assembled.
- Keep packaging materials away from children during installation.
- Allow fitting to cool before handling if recently operated.
- Isolate power before cleaning, maintenance, or inspection.
- Failure to follow installation instructions may result in electric shock, fire hazard, product failure, or voided warranty.
- Visit www.havit.com.au for full Warranty Terms & Conditions.

2 Technical Specifications

PART NUMBER	COLOUR TEMP.	LUMEN OUTPUT	INCLUDED LED	INPUT
HV10293T HV10393T	3000K	2 × 280 lm	2 × 3W · Built-in LED	240V AC
	4000K	2 × 310 lm		
	5500K	2 × 310 lm		

CONSTRUCTION

Body material	Aluminium
Finish	Poly powder-coated Black or White
Fixings	Stainless grub screws
Backing plate	Matching, supplied

RATINGS

Ingress protection	IP65
Total power	6W (2 × 3W)
Beam direction	Up & Down
Suitability	Indoor / Outdoor

3 Product Dimensions

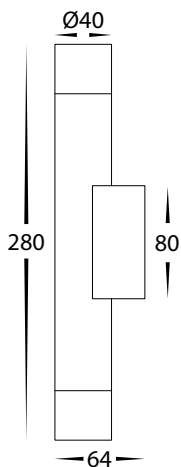

Overall height	280 mm
Body diameter	Ø 40 mm
Mounting plate (W × H)	33 × 73 mm
Mounting hole spacing	61 mm (vertical)
Cable entry	Ø 11 mm
Mounting holes	2 × Ø 4.8 mm

All dimensions are nominal and in millimetres. Verify against the physical product before drilling.

4 Safety Warnings

! IMPORTANT — READ BEFORE INSTALLATION

This is a 240V mains-voltage fitting. In Australia and New Zealand, fixed mains wiring must be carried out by a licensed electrician in accordance with AS/NZS 3000 (Wiring Rules). Do not attempt to wire or connect this product yourself.

Isolate mains power and lock-off / tag the circuit before wiring.

Confirm the supply matches the rating: 240V AC, 50Hz.

Do not connect a damaged fitting. Inspect the body, lens and gasket before install.

The integrated LED is not user-replaceable; do not open the sealed LED module.

Maintain the IP65 seal — fit the supplied gasket and seal the cable entry correctly.

5 In the Box

SUPPLIED

1 × HV10293T or HV10393T Light Fitting

Sealing gasket - Attached to Backing Plate

1 × Matching backing plate - Attached to Fitting

2x wall plugs

Stainless steel grub screws - Attached to Fitting

2.5mm hex (allen) key

6 Mounting Template

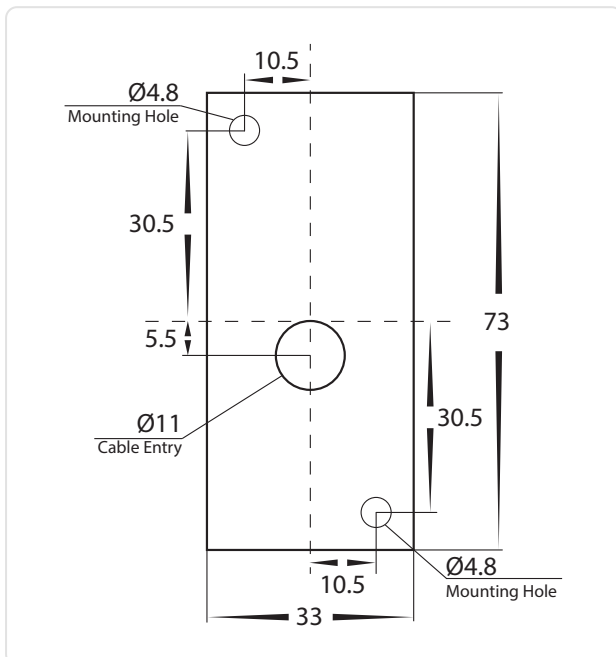

The backing plate has two Ø4.8 mm mounting holes and an almost central Ø11 mm cable entry. Mark the wall using the plate itself, or transfer the dimensions shown:

Mounting holes	2 × Ø 4.8 mm
Hole vertical spacing	61 mm
Hole offset from centre	10.5 mm
Cable entry diameter	Ø 11 mm
Cable entry from centre	5.5 mm below

i NOTE

Diagram is not to scale when printed. Always verify dimensions against the physical backing plate before drilling.

7 Installation Procedure

TRI-COLOUR SELECTOR



SET COLOUR TEMPERATURE FIRST

Use the TRI-colour selector switch on the fitting to choose 3000K, 4000K or 5500K **BEFORE** mounting. Match all fittings on the same façade for a consistent look.

1

Isolate the Power

Switch off the circuit at the switchboard, lock-off / tag it, and confirm the wiring is de-energised with a voltage tester.

2

Remove Backing Plate

Remove backing plate from fitting by loosening Allen Screws on side of fitting.

3

Select Colour Temperature

Set the TRI-colour switch to your chosen CCT located in back of fitting. Must be done before the body is fixed to the wall.

4

Mark & Prepare Surface

Use the backing plate (or template dimensions) to mark the Ø4.8 fixing holes and Ø11 cable entry. Drill and insert wall plugs.

5

Feed the Supply Cable

Route mains cable through the cable entry / gland. Fit the gasket to maintain the IP65 seal against the wall.

6

Secure the backing plate

Fix the plate flush and level. Apply exterior silicone to the top and side edges for outdoor installs. also apply silicon to all fixing points and cable entry

7

Connect the wiring

Electrician connects Active, Neutral & Earth to the matching terminals (see below) and confirms tight, insulated joints.

8

Mount the body

Tuck excess cable behind the fitting, locate the body onto the plate and lock with the stainless grub screws.

9

Restore power & test

Re-energise and confirm both up and down LEDs illuminate. Check the fitting is secure and sealed.

TERMINAL BLOCK

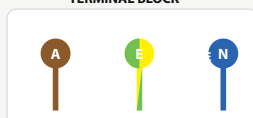

WIRING CONNECTIONS

Connect supply to matching terminals. Conductor colours per AS/NZS 3000:

■ Active — Brown ■ Earth — Green/Yellow ■ Neutral — Blue

8 Maintenance & Care

Always isolate power before cleaning or inspecting the fitting.

Wipe the body and lens with a soft, damp cloth — avoid solvents and abrasives that may damage the powder-coat finish.

Periodically check the gasket is intact and the fitting remains sealed, especially in exposed locations.

Inspect grub screws are secure and the body has not loosened over time.

9 Troubleshooting

SYMPTOM	POSSIBLE CAUSE	ACTION
Light does not turn on	Circuit not energised / wiring loose	Confirm power is on and have the electrician check terminal connections.
Only one direction working	Internal connection / faulty module	Isolate power, re-seat the body; if it persists, lodge a warranty claim.
Flickering	Loose connection or supply issue	Electrician to check connections and supply stability.
Wrong colour temperature	TRI-colour switch position	Isolate, remove body and reset the CCT selector switch.
Moisture inside lens	Compromised IP65 seal	Check gasket seating and cable gland sealing; re-seal as needed.

9 Warranty

3 YEARS

REPLACEMENT WARRANTY

IP65

INGRESS PROTECTION

240V

MAINS INPUT

This product carries a 3-year replacement warranty from Havit Lighting. Warranty applies to the original purchaser and is subject to correct installation by a licensed electrician and normal use in accordance with these instructions. Full warranty terms & conditions and product registration are available at havit.com.au. Retain your proof of purchase.

i REGISTER YOUR PRODUCT

Register your purchase and access data sheets, IES files and the latest installation documents at havit.com.au/pages/resources.



143 Beauchamp Road, Matraville NSW 2036
 Phone: +61 (02) 9381 8300
 Email: Sales@havit.com.au
 Web: havit.com.au



Warranty Terms & Conditions



www.havit.com.au