

# 12W DALI 2 SURFACE MOUNTED LED DOWNLIGHTS

Web: [www.havitcommercial.com.au](http://www.havitcommercial.com.au)  
 Email: [sales@havitcommercial.com.au](mailto:sales@havitcommercial.com.au)  
 Phone: 02 9381 8383

ADDRESS: 8/133 Beauchamp Road, Matraville, N.S.W., 2036



Warranty T & Cs



Website



# 12W DALI 2 SURFACE MOUNTED LED DOWNLIGHTS ACCESSORIES

Web: [www.havitcommercial.com.au](http://www.havitcommercial.com.au)  
 Email: [sales@havitcommercial.com.au](mailto:sales@havitcommercial.com.au)  
 Phone: 02 9381 8383

ADDRESS: 8/133 Beauchamp Road, Matraville, N.S.W., 2036



Warranty T & Cs



Website



PRODUCT SPECIFICATIONS	
MATERIAL	ALUMINIUM
COLOUR	BLACK OR WHITE
IP RATING	IP54
IK RATING	IK08
INSTALLATION TYPE	CEILING - SURFACE MOUNTED
DIFFUSER TYPE	PLASTIC
LAMP BASE	BUILT IN LED
MAX WATTAGE	12W
PROTECTION CLASS	240V = 1 (REQUIRES EARTH)
LAMP EXPECTANCY	<50,000HRS*
SDCM	<3
UGR	<10
CRI	CRI>90
DIMMABLE	YES - DALI 2
WARRANTY	5 YEARS REPLACEMENT*

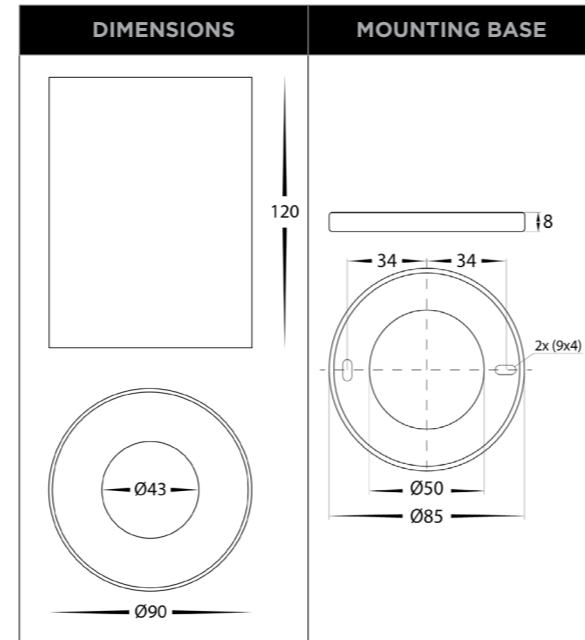

## PRODUCT ORDERING

IMAGE	PART NUMBER	COLOUR TEMP	LUMENS	INPUT VOLTAGE	BEAM ANGLE	INCLUDED LED	BARCODE
	HCP-8921224	2700K 3000K 4000K 5000K 5700K	688LM 840LM 916LM 931LM 1004LM	240V AC	60°	FIVE COLOUR 12W BUILT IN LED	9350418083234
	HCP-8931224			240V AC			9350418083241



## WHITE



## BLACK



HCP-89012-BLK-PDT  
3M PENDANT ACCESSORY

HCP-89012-WHT-PDT  
3M PENDANT ACCESSORY

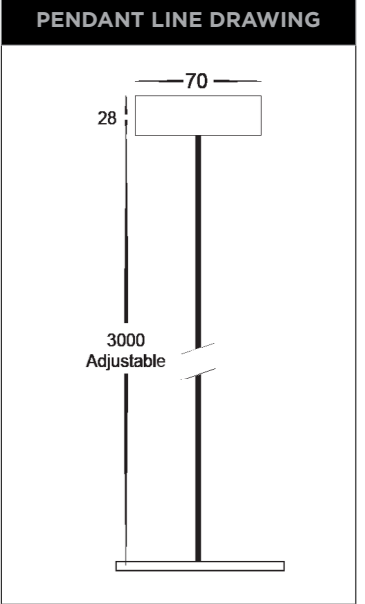

## OPTIONAL COMPATIBLE HAVIT ACCESSORIES

IMAGE	PART NUMBER	DESCRIPTION	BARCODE
	HCP-89012-GR	GOLD INSERT	9350418083272
	HCP-89012-BR	BLACK INSERT	9350418083289
	HCP-89012-CR	CHROME INSERT	9350418083296
	HCP-89012-BLK-PDT	3M PENDANT ACCESSORY	9350418090089
	HCP-89012-WHT-PDT	3M PENDANT ACCESSORY	9350418090096

ALSO AVAILABLE IN 7W, 18W AND 24W MODELS.  
 \*SEE WARRANTY TERMS & CONDITIONS FOR MORE INFORMATION