

# 12W ALUMINIUM WHITE RECESSED LED DOWNLIGHT

Web: [www.havitcommercial.com.au](http://www.havitcommercial.com.au)  
 Email: [sales@havitcommercial.com.au](mailto:sales@havitcommercial.com.au)  
 Phone: 02 9381 8383

ADDRESS: 8/133 Beauchamp Road, Matraville, N.S.W., 2036



Warranty T & Cs



Website



## PRODUCT SPECIFICATIONS

MATERIAL	ALUMINIUM
COLOUR / FINISH	WHITE
INSTALLATION TYPE	CEILING - RECESSED
CUT OUT	Ø90MM
COLOUR TEMP	3000K   4000K   5700K
LUMENS	1150LM   1160LM   1190LM
INPUT VOLTAGE	240V (SUPPLIED WITH FLEX & PLUG)
PROTECTION CLASS	2 (NO EARTH REQUIRED)
LAMP BASE	BUILT IN 12W LED
DIMMING	TRIAC DIMMABLE
CRI	RA >90
BEAM ANGLE	100°
IP RATING	IP44
IK RATING	IK04
LAMP EXPECTANCY	>50,000HRS*
SDCM	<6
UGR	<27
IC RATING	IC-4
TILT	NO TILT
WARRANTY	5 YEARS REPLACEMENT*

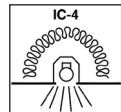
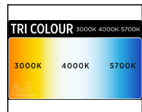

## PRODUCT ORDERING

	HCP-8231212	3000K 4000K 5700K	1150LM 1160LM 1190LM
---	-------------	-------------------------	----------------------------

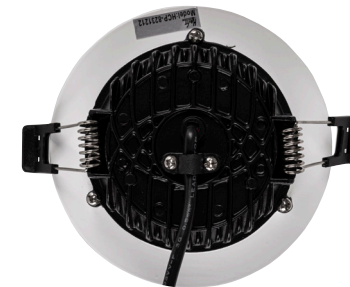

## DIMENSIONS

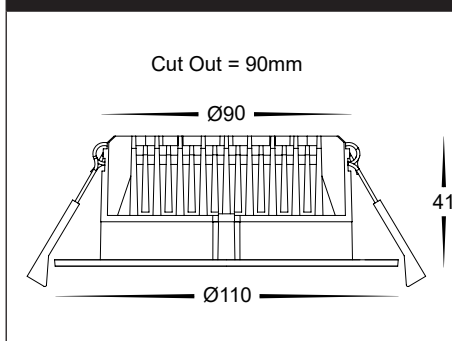

## SAMPLE INSTALLATION DIAGRAM

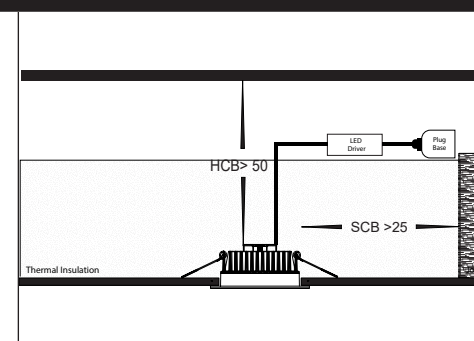

3000K

4000K

5700K