

HCP-79233

Dual Sensor Stair Light Controller

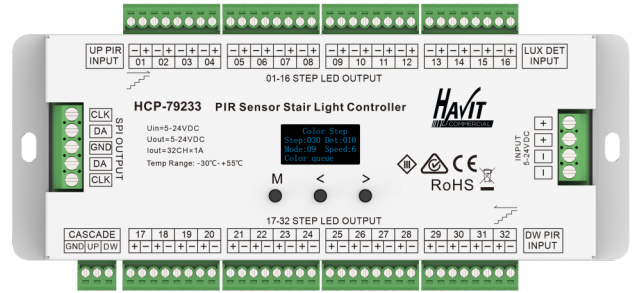

- Multi-function dual sensor stair light controller features daylight sensor.
- 32 channels constant voltage output drive low voltage LED strip, Max. 1A current per channel.
- 2 groups same SPI(TTL) signal output, drive 28 kinds IC digital RGB LED strip, IC type and R/G/B order can be set.
- Compatible ICs: TM1804, TM1809, TM1812, UCS1903, UCS1909, UCS1912, UCS2903, UCS2909, UCS2912, WS2811, WS2812, TM1829, TM1914A, GW6205, GS8206, GS8208, LPD6803, LPD1101, D705, UCS6909, UCS6912, LPD8803, LPD8806, WS2801, WS2803, P9813, SK9822, SM16703P.
- Easy operation with OLED display and 3 buttons.
- four work light modes selectable.
- Two stair light controllers can cascade.
- Built-in multiple color mode, speed and brightness 1-8 grade adjustable.
- Push switch can be used as induction signal input.
- With fast self-testing function / Over-heat / Short circuit protection.
- Any damaged LED channel in 32 channels can be set disable.
- Use with two laser sensing heads(EL-C) or 2 PIR motion sensing heads (ER-C).



CE RoHS

Technical Parameters

Input and Output		Environment		Safety and EMC	
Input voltage	5-24VDC	Operation temperature	T _a : -30°C ~ +55°C	EMC standard	EN IEC 55015/EN IEC 61547
Output voltage	32 x (5-24)VDC	Case temperature (Max.)	T _c : +85°C	Safety standard	EN 61347-1/-2 EN 62493
Output current	32CH, 1A/CH	IP rating	IP20	Certification	CE RoHS
Output power	32 x (5-24)W	Package			
Output type	Constant voltage + SPI(TTL)	Size	L200 x W90 x H70mm		
Warranty		Gross weight	0.66kg		
Warranty	5 years				

Mechanical Structures and Installations

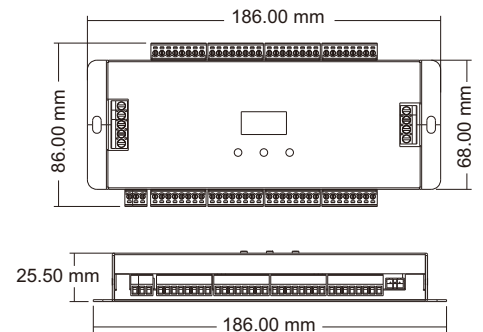
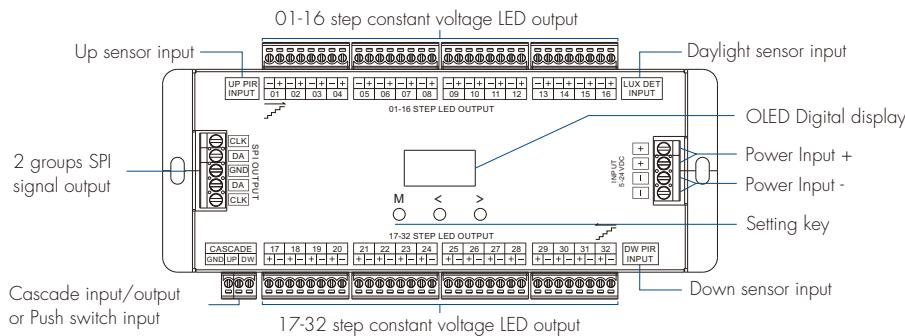

Wiring Diagram

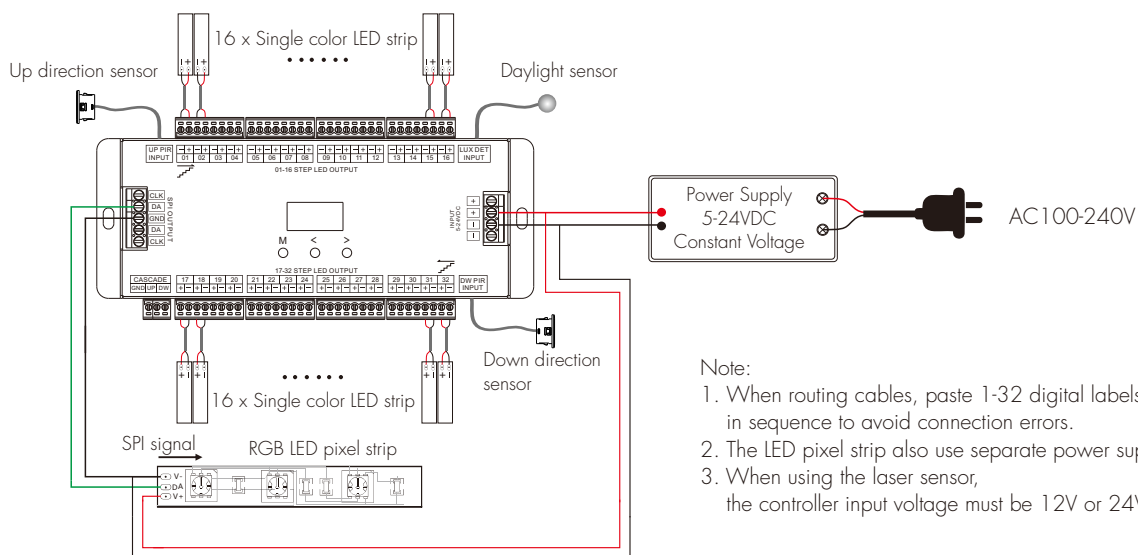

- Note:
1. When routing cables, paste 1-32 digital labels on the output lines in sequence to avoid connection errors.
 2. The LED pixel strip also use separate power supply.
 3. When using the laser sensor, the controller input voltage must be 12V or 24V.

OLED Screen and Key Operations

1. Long press M key for 2s, enter system parameters setting state, to switch four work light modes, set light off mode, push switch input function, chip type and RGB order or daylight sensor threshold.
2. Short press M key, enter current work light mode parameters setting state.
3. When in parameters setting state, short press M key to switch multiple parameters, press < or > key for parameters' adjustment.
4. Long press M key or wait 1.5s to quit parameter setting state.
5. Long press M & > key for 2s, display "Light up test" on the 4 line of OLED screen, start up direction induction light testing.
6. Long press M & < key for 2s, display "Light down test" on the 4 line of OLED screen, start down direction induction light testing.
7. Long press < & > key for 2s, restore factory default parameters, jump to language interface automatically, press < or > to switch two languages(Chinese and English), press M key to exit language interface.
8. Long press <, > & M for 2s, enter 32 channels LED disable setting interface.
9. When work in White Step/Color Flow/Color Step/White Step + Color Flow mode, the 4 line display color mode name. When the controller is in induction state, the indication of inductive signal input ("Light up start" and "Light down start") is displayed first, and then the light on/off status is displayed. If the current detected LUX value is greater than daylight sensor threshold, display "Light up off" or "Light down off" on the fourth line.



Language interface



Light on/off state on the 4 line

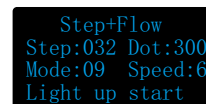

Inductive indication on 4 line

System Parameters Setting

Out: Switch four work light modes.

White_Step: Only multiple constant voltage LED strip light mode.

Color_Flow: Only 1 or 2 straight line digital pixel LED strip light mode.

Color_Step: Only multiple Z-shape digital pixel LED strip light mode.

Step+Flow : Multiple constant voltage LED strip + 1 or 2 straight line digital pixel LED strip light mode.

Chip: Select one chip type from ten options (shown in below table) one of these from 6 RGB orders (RGB,RBG,GRB,GBR,BRG,BGR). The parameters are valid only for the work modes with SPI signal output.

Def RGB: RGB hex value for user-define color. The parameters are valid only for the work modes with SPI signal output.

LuxSet: Daylight sensor threshold (10, 30, 50, 100, 150, 200lux, OFF), with sufficient ambient light, the PIR sensor does not turn on the light. Daylight sensor default off. The digital value after * is current detected LUX value.

OFF: Set 3 types of lights off and delay time at the end of sensing.

Delay sync: Lights are synchronized off with a delay time.

One by one: Lights turn off sequentially from the end to the head with a delay time.

Repeat run: The lights run in a loop until the delay ends.

Delay time: 5s, 10s, 15s, 20s, 30s, 1min, 3min, 5min, 10min, cancel. Set cancel means not turn off the light.

Push: Switch two kinds of push switch input modes.

Cascade: The push switch input work as cascade input/output or simulated PIR inductive input.

All-on: The push operation will turn on all light and turn off synchronously after the delay time.

Digital pixel RGB LED strip compatible IC types list:

IC type	Compatible IC type	Output signal
TM1809	TM1804, TM1812, UCS1903, UCS1909, UCS1912, UCS2903, UCS2909, UCS2912, WS2811, WS2812, SM16703P	DATA
TM1829		DATA
TM1914A		DATA
GW6205		DATA
GS8206	GS8208	DATA
LPD6803	LPD1101, D705, UCS6909, UCS6912	DATA, CLK
LPD8803	LPD8806	DATA, CLK
WS2801	WS2803	DATA, CLK
P9813		DATA, CLK
SK9822		DATA, CLK

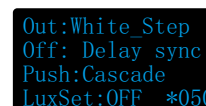

System parameters interface of White step mode

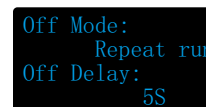

Switch-off method and delay time setting



System parameters interface of White step + Color flow mode

LED Channel Output Disable Setup

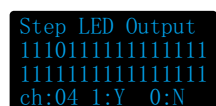

ch: the channel which is set
 1: enable the channel to work
 0: disable the channel

For example: If the fourth channel output is damaged, please long press M, < & > key to enter LED disable interface, then change the corresponding channel(04) from 1(on) to 0(off). namely the damaged channel can be ignored.

1.White Step Mode(Constant voltage LED strip light mode)

```
White Step
Step:032 Bri:8
Mode:01 Speed:6
ON one by one
```

Step: Total step number, 008-032
Mode: White mode number, 01-04
Bri: Brightness grade,
 1-8, 8 is the brightest level.
Speed: Speed grade,
 1-8, 8 is the fastest speed.

White mode list:

No.	Name
01	ON one by one
02	All OFF, Five ON
03	All ON, one OFF
04	All ON

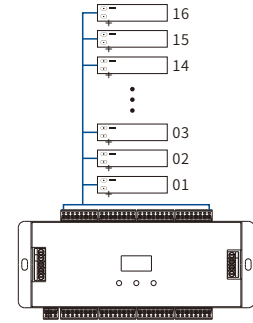

2.Color Flow Mode (Straight line digital pixel LED strip light mode)

```
Color Flow
Dot: 300 Bri:8
Mode:09 Speed:6
Color queue
```

Dot: Pixel dot number, 032-960
Mode: Color mode number, 01-12
Bri: Brightness grade,
 1-8, 8 is the brightest level.
Speed: Speed grade,
 1-8, 8 is the fastest speed.

Color mode list:

No.	Name
01	Red
02	Orange
03	Yellow
04	Green
05	Cyan
06	Blue
07	Purple
08	White
09	Color queue (7 color + White)
10	Color chase(7 color + White)
11	Color fade (6 color flow)
12	Rxxx Gxxx Bxxx (User define)

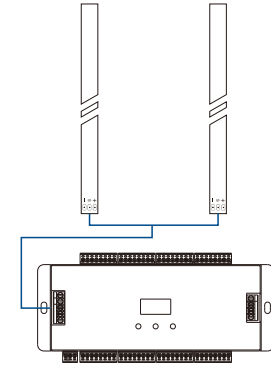

3.Color Step Mode(Z-shape digital pixel LED strip light mode)

```
Color Step
Step:030 Dot:010
Mode:09 Speed:6
Color queue
```

Step: Total step number, 008-160
Dot: Pixel dot number of each step, 002-120
 The Step number x Dot number must < 960
Mode: Color mode number, 01-12
Speed: Speed grade,
 1-8, 8 is the fastest speed

Color mode list:

No.	Name
01	Red
02	Orange
03	Yellow
04	Green
05	Cyan
06	Blue
07	Purple
08	White
09	Color queue (7 color + White)
10	Color chase (7 color + White)
11	Color fade (6 color fade)
12	Rxxx Gxxx Bxxx (User define)

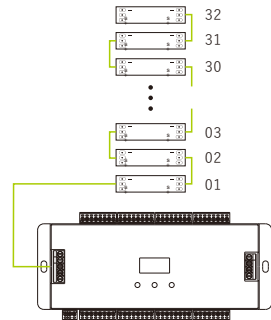

4.White Step + Color Flow Mode(Constant voltage LED strip + Straight line digital pixel LED strip light mode)

```
Step+Flow
Step:032 Dot:300
Mode:09 Speed:6
Color queue
```

Step: Total step number, 008-032
Dot: Pixel dot number, 032-960
Mode: Color mode number, 01-12
 The mode number is for straight line digital pixel LED strip only.
 The mode for constant voltage LED strip is fixed on one by one.
Speed: Speed grade,
 1-8, 8 is the fastest speed.

Color mode list:

No.	Name
01	Red
02	Orange
03	Yellow
04	Green
05	Cyan
06	Blue
07	Purple
08	White
09	Color queue (7 color + White)
10	Color chase (7 color + White)
11	Color fade (6 color flow)
12	Rxxx Gxxx Bxxx (User define)

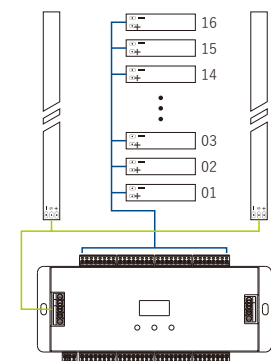

Laser Sensor Head

Features

- 3-wire laser sensor head, powered by low voltage 5VDC, output high or low level.
- When the sensor head detects the person or object in front of it, it will output high level.
- Detection distance 0.05-2.5m, sensing angle $\pm 10^\circ$.
- Auto ranging and manual ranging modes are available.
- Set the sensing detection distance by powering up or pressing the key.
- Six delay times can be set (2, 5, 10, 30, 60, 0s).
- Suitable for lighting staircases, courtyards, aisles, corners, corridors, etc.



Mechanical Structures

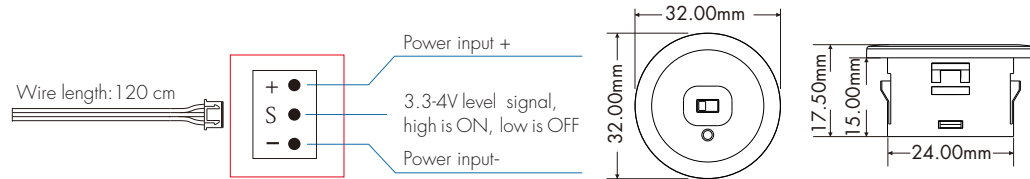

SET Key Function

Detection distance setting:

The detection distance range is 0.05-2.5m, and switch auto or manual ranging modes by double click the SET key.

Auto ranging (factory default mode):

The distance is automatically detected and set every time the power is on, and the distance parameter is not memorised.

If there is no obstacle in front of the sensor head at the time of power-on, the detection distance is automatically set to 2.5 m.

If there is an obstacle in front of the sensor head at the time of power-on, for example: the sensor head is 1 m away from the wall in front of it, the detection distance is automatically set to 1 m.

You can also set the detection distance by pressing the SET key within 60 seconds of powering up the sensor head, the distance parameter is only for temporary use and is not memorised.

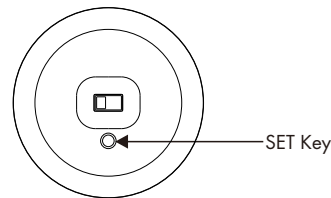

Manual ranging:

Double click the SET key after power on, switch to manual distance measurement mode, the output LED blinks 3 times.

Then short press the SET key, the distance measurement will be completed within 2 seconds and the distance parameter will be saved, the output LED will flash 1 time.

Double click the SET key again to return to automatic ranging mode, the output LED will flash 2 times.

Manual ranging remembers the last saved distance parameter, which is suitable for the scenarios where the detection distance needs to be fixed (e.g. locking the detection range after the device is installed).

Note: When short press the SET key to measure the distance, people should not block in front of the sensor head.

Delay time setting:

Within 60 seconds of powering up the sensor head,

long press the SET key for 2 seconds to set 6 delay times (2, 5, 10, 30, 60, 0 seconds).

When set to 2 seconds delay time, the indicator and output LED will flash once;

When set to 5 seconds delay time, the indicator and output LED will flash twice;

When set to 10 seconds delay time, the indicator and output LED will flash 3 times;

When set to 30 seconds delay time, the indicator and output LED will flash 4 times;

When set to 60 seconds delay time, the indicator and output LED will flash 5 times;

When set to 0 seconds delay time, the indicator and output LED will flash 6 times;

Note:

1. The first long press after powering up the sensor head does not change the delay time, but only indicates the current delay time by flashing the light.
2. The factory default delay time is 2 seconds, i.e., after the human body/objects leave the sensing range, the output signal will become low after 2 seconds delay.

Sensor Head Installation Position

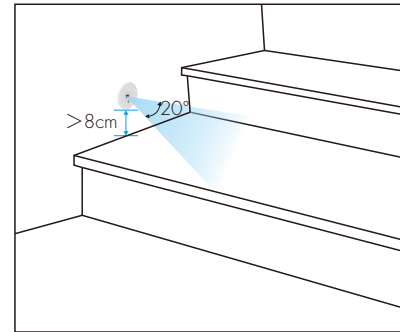

When installing on stairs, install at a height of 8cm or more, as far away from the foot elevation as possible. Make sure that your foot steps up just enough to block the laser and trigger the sensor to light up.

Sensor Head Installation and Application

- One ELC sensor head + one E1-L sensor constant voltage LED controller

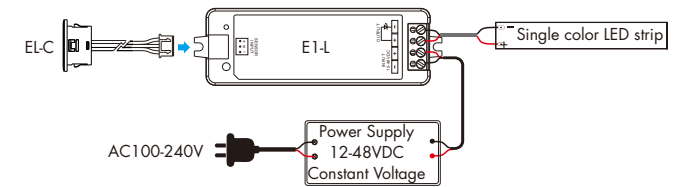
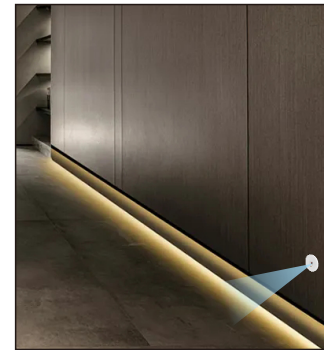

For a single application, it is recommended to set the delay time of the laser sensor head to 30 or 60s. Realize people come and light up, and turn off the light at a delayed time when people leave.

• Multiple ELC sensor head + multiple E1-L sensor constant voltage LED controller

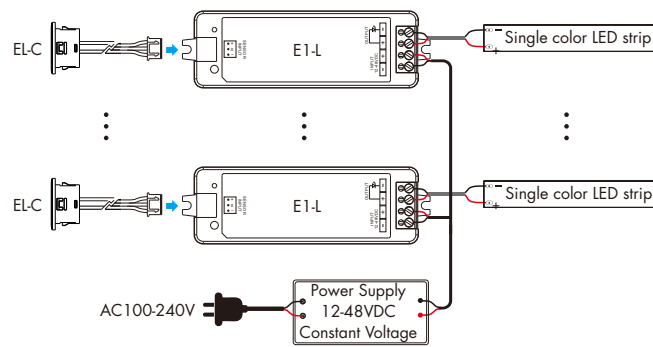
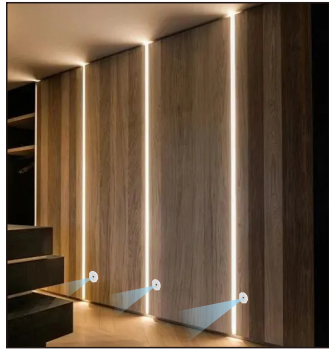

For multiple applications, it is recommended to set the delay time of all laser sensor head to 5 or 10s. Realize the sequential switching control of multiple lights according to the direction of human walking.

• Dual ELC sensor head + ES32 sensor stair light controller

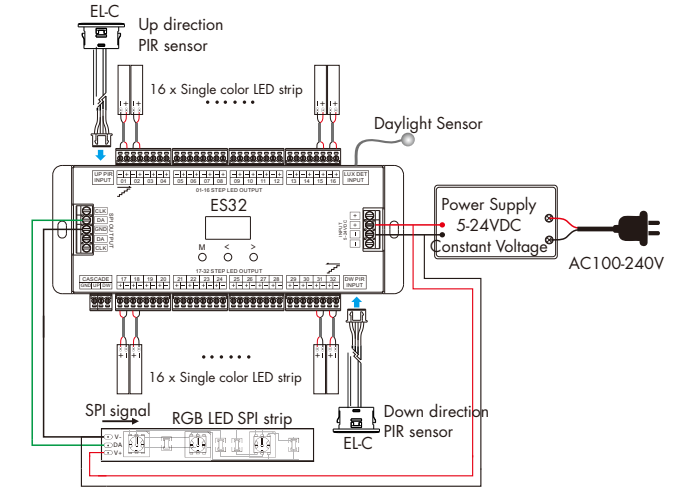
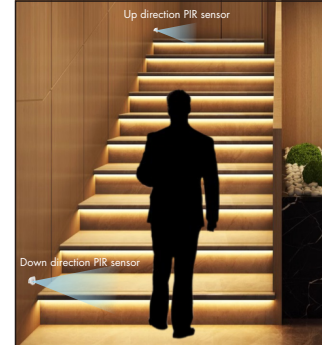

Connect the ES32 sensor stair light controller to two laser sensor head, which are installed at the top and bottom of the stairs. Set the delay time of the laser sensor head to 2s (default). Set the delay off time by the OLED screen(5s, 10s, 15s, 20s, 30s, 1min, 3min, 5min, 10min). Achieve sequential switching control of multiple staircase lights.

• Dual ELC sensor head + ES-V dual sensor Dimming & CCT constant voltage LED controller

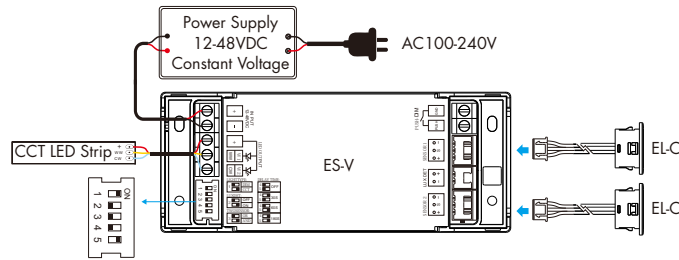
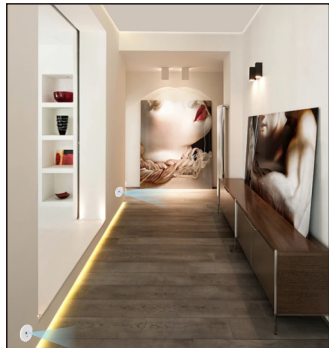

The ES-V constant voltage controller is connected to two laser sensor head which are installed on each side of the corridor. The delay time of the laser sensor head is set to 2s (default value), Set DIP switch 3 to OR (light on when any one of the sensing inputs is on). Set DIP switch 4-5 to 30, 60 or 180s. Realize the light will be on when people come to the corridor and turn off the light when people leave. Note: Since the detection distance of the sensor head is 2.5 meters, when the width of the corridor or staircase is 2.5-5m, two sensor head can be installed opposite to each other.

Installation Precaution

1. The sensing head should be installed in a dry environment and keep away from windows, air conditioner and fans.
2. The sensing head should be installed in the correct direction and angle.
3. There should not be shelter(screen, furniture, large bonsai) within the range of detection.
4. Avoid touching the surface of the detector and clean the surface of the optical lens with a damp soft cloth or cotton cloth regularly to prevent dust from affecting the sensitivity.
5. This product is not fireproof, do not immerse in water or use near fire source.

Installation of Laser PIR Sensor

Laser Sensor EL-C Size of detector:

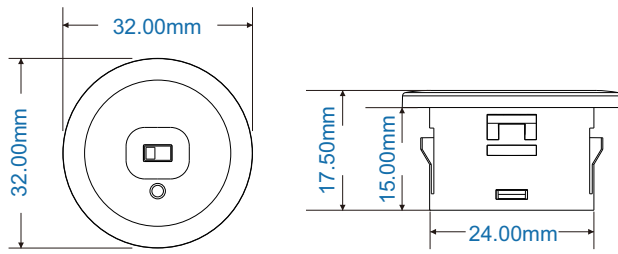

Sensitive Field: 0.05-2.5m, Sensitivity Angle: 20°

Laser sensor detection scope:

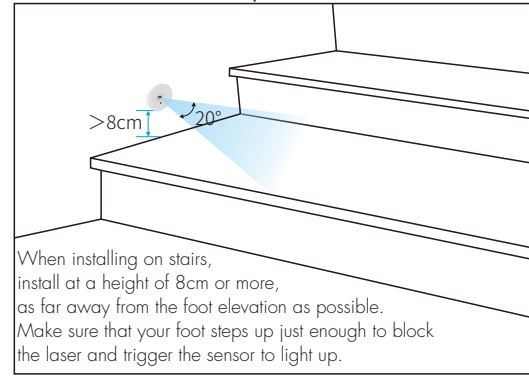

Notice for installation of laser sensor

1. The sensing head should be installed in a dry environment and keep away from windows, air conditioner and fans.
2. The sensing head should be installed in the correct direction and angle.
3. There should not be shelter (screen, furniture, large bonsai) within the range of detection.
4. Avoid touching the surface of the detector and clean the surface of the optical lens with a damp soft cloth or cotton cloth regularly to prevent dust from affecting the sensitivity.
5. This product is not fireproof, do not immerse in water or use near fire source.

PIR Motion Sensor ER-C

Size of detector:

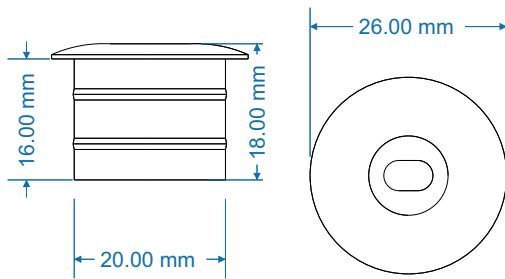

Sensitive Field: ≤3m, Sensitivity Angle: 30°(±10°)

PIR sensor detection scope (±10° Error):

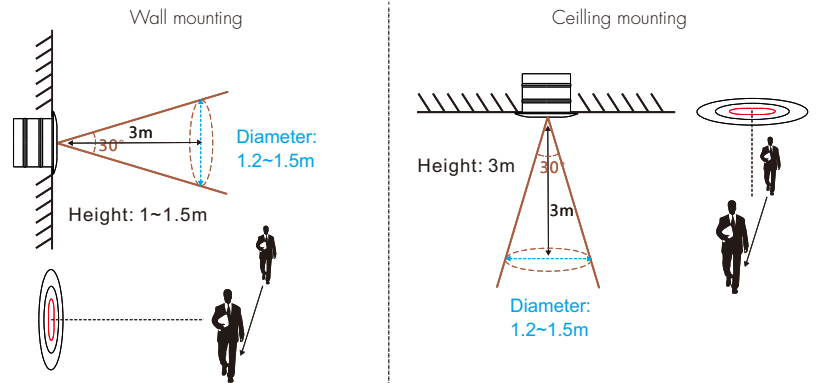

- ★ For wall mounting and ceiling mounting,
- ★ note that the sensing holes are perpendicular to the direction of human movement.

Two Stair Light Controller Cascade Connection

The downstairs light controller connects up direction sensor and daylight sensor.
The upstairs light controller connects down direction sensor and daylight sensor.
Two stair light controllers connect cascade UP/DW line.
After the sensing light control process is finished, wait for the delay time, the light will automatically turn off.

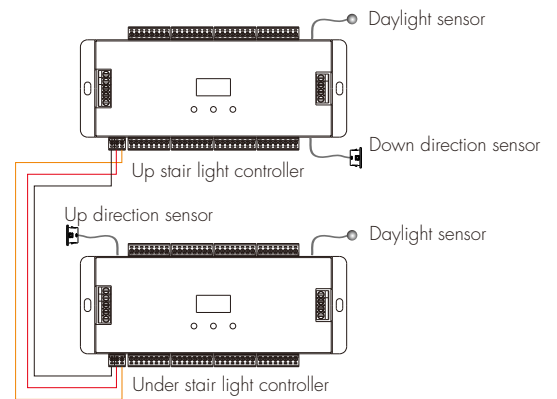

Note: The push switch function must be set as cascade input.

Two Push Switch as Up/Down Induction Signal Input Connection

The under push switch connect cascade UP port of the stair light controller.
The up push switch connect cascade DW port of the stair light controller.
The push switch operation will ignore daylight sensor threshold setting.

When the push switch function be set as cascade input, the push operation will start induction light control process.

When the push switch function be set as All-on input, the push operation will turn on all light, and the light will turn off after the delay time automatically.

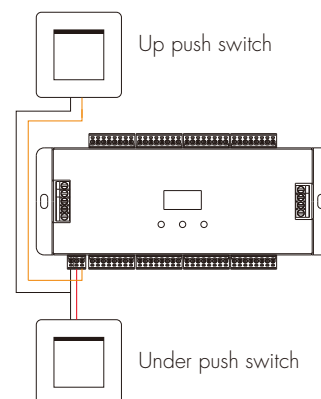

Notice for installation of PIR sensor

1. Recommended for wall mounting.
2. If the sensor is exposed to direct sunlight, interference signal will be introduced.
3. The sensor should be installed in a dry environment and keep away from windows, air conditioner and fans.
4. Make sure that the sensor stays away from heat source, such as countertops, kitchen appliances which generate hot steam, walls and windows in direct sunlight, air conditioner, heating, refrigerators, stoves and so on.
5. We recommended the wall-mounted installation height is 1-1.5 meters and the ceiling mounting height is no more than 3 meters.
6. There should not be shelter(screen, furniture, large bonsai) within the range of detection.

Packing List

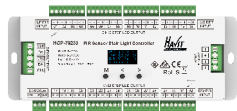

LED Controller
1 pcs

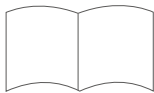

User Manual
1 pcs



Daylight sensor
(30cm)
1 pcs



Laser sensor
(1m)
2 pcs

or



PIR sensor
(1.2m)
2 pcs



Sensor
extension line (5m)
2 pcs



Slotted
screwdriver
1 pcs
