

24V DC 150W DALI 2 + PUSH DIM CONSTANT VOLTAGE DIMMABLE LED DRIVER

Web: www.havitcommercial.com.au
Email: sales@havitcommercial.com.au
Phone: 02 9381 8383

ADDRESS: 8/133 Beauchamp Road, Matraville, N.S.W., 2036



Warranty T & Cs



Website



PRODUCT SPECIFICATIONS

PART NUMBER	HCP-522531
MATERIAL	ALUMINIUM
COLOUR / FINISH	ANODISED GREY
INPUT VOLTAGE	100 - 240V AC
OUTPUT VOLTAGE	24V DC CONSTANT VOLTAGE
DIMMING	YES (DALI 2 + PUSH DIMMING)
DIMMING RANGE	5%-100%
OVERLOAD PROTECTION	YES
SHORT CIRCUIT PROTECTION	YES
OVER VOLTAGE PROTECTION	YES
WORKING TEMP	-25°C TO +50°C
DRIVER POWER	150W
RECOMMENDED MAX. LOAD	120W
IP RATING	IP66
WARRANTY	5 YEARS REPLACEMENT



DIMENSIONS

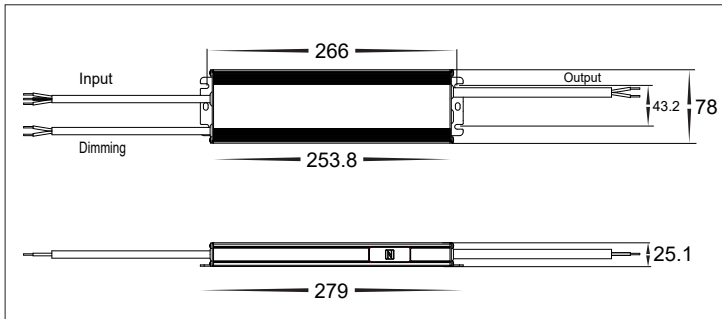

SAMPLE WIRING DIAGRAM

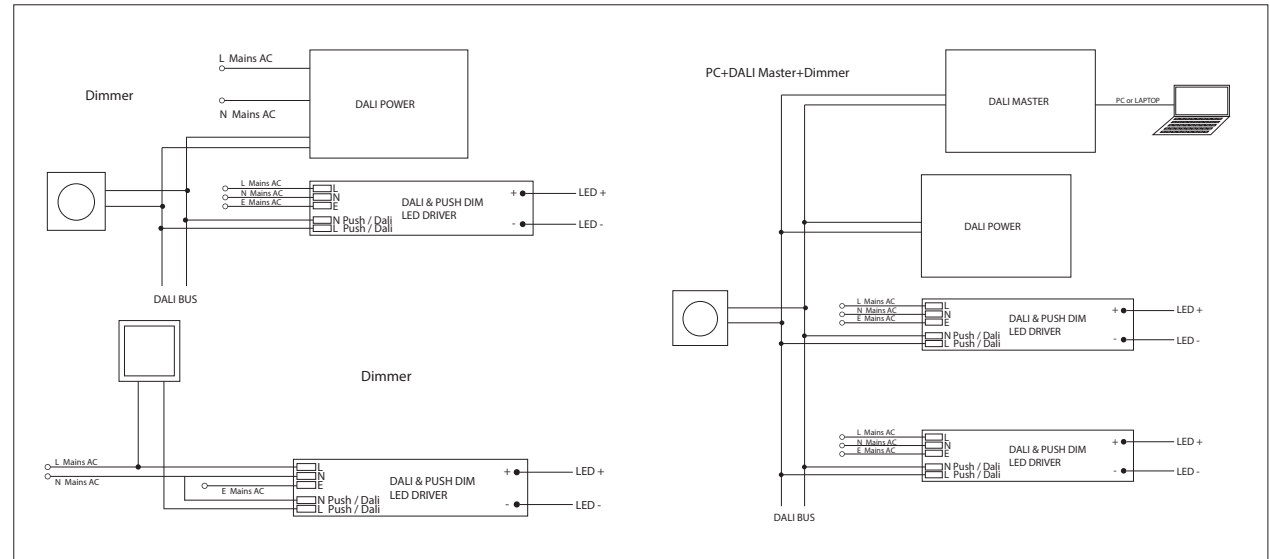

24V DC 150W DALI 2 + PUSH DIM CONSTANT VOLTAGE DIMMABLE LED DRIVER

Web: www.havitcommercial.com.au
Email: sales@havitcommercial.com.au
Phone: 02 9381 8383

ADDRESS: 8/133 Beauchamp Road, Matraville, N.S.W., 2036



Warranty T & Cs



Website



DRIVER TECHNICAL INFORMATION

OUTPUT	DC VOLTAGE	24V (24-26V ADJUST BY NFC)
	RATED CURRENT	6.25A
	RATED POWER	150W
	LOAD REGULATION	±2%
INPUT	VOLTAGE RANGE	100-277V AC
	FREQUENCY RANGE	47-63hz
	THD(Typ.) @ FULL LOAD	≤10% @ 120V AC ≤10% @ 230V AC ≤15% @ 277V AC
	POWER FACTOR (TYP.)	PF≥0.98 @ 120V AC PF≥0.95 @ 230V AC PF≥0.90 @ 277V AC (Full Loading)
	EFFICIENCY (TYP.)	88% @ 120V AC 90% @ 230V AC 90% @ 277V AC
	AC CURRENT (MAX)	1.65A
	INRUSH CURRENT (TYP.)	38.4A, 510us@50% Ipeak (120V AC)
		88A, 120us@50% Ipeak (230V AC)
48A, 560us@50% Ipeak (277V AC)		
LEAKAGE CURRENT	0.5mA	
PROTECTION	OVERLOAD	<120%, SHUT DOWN O/P VOLTAGE, REPOWER ON TO RECOVER AFTER FAULT IS REMOVED
	SHORT CIRCUIT	HICCUP MODE, RECOVER AUTOMATICALLY AFTER FAULT CONDITION IS REMOVED
	OVER TEMPERATURE	AMBIENT TEMPERATURE OVER 55°C ± 10°C, OUTPUT WILL TURN OFF AND RECOVERS AUTOMATICALLY AFTER TEMPERATURE DROPS.
	PROTECTION CLASS	1
ENVIRONMENT	WORKING TEMPERATURE	TA: -40°C - +60°C
	WORKING HUMIDITY	20%-90%RH, NON CONDESNING
	STORAGE TEMP. & HUMIDITY	-40°C - +80°C / 10% - 95%RH
	TEMP. COEFFICIENT	±0.03%/°C (0-50°C)
	VIBRATION	10-500Hz, 2G 10MIN./1 CYCLE, PERIOD FOR 60MIN. EACH ALONG X, Y, Z AXES
SAFETY & EMC	SAFETY STANDARDS	COMPLIANCE TO EN61347-1, EN61347-2-13, AS/NZS61347-1 IP66 WATERPROOF RATING
	WITHSTAND VOLTAGE	I/P-O/P, I/P-FG, O/P-FG: 100Mohms/500Vdc 25°C/70%RH
	EMC EMISSION	COMPLIANCE TO AS/NZS CISPR15
	INSULATION RESISTANCE	I/P-O/P I/P-FG O/P-FG:100MΩ/500VDC/25°C/70%RH
	EMC IMMUNITY	COMPLIANCE TO AS/NZS CISPR15

