

24V DC 150W TRIAC + 0-1/10V DIMMABLE LED DRIVER

Web: www.havitcommercial.com.au
 Email: sales@havitcommercial.com.au
 Phone: 02 9381 8383

ADDRESS: 8/133 Beauchamp Road, Matraville, N.S.W., 2036



Warranty T & Cs



Website



PRODUCT SPECIFICATIONS

PART NUMBER	HCP-52252
MATERIAL	ALUMINIUM
COLOUR / FINISH	GREY
INPUT VOLTAGE	240V AC (SUPPLIED WITH FLEX & PLUG)
OUTPUT VOLTAGE	24V DC CONSTANT VOLTAGE
DIMMING	YES (TRIAC +0-1/10V DIMMING)
DIMMING RANGE	10%-100%
OVERLOAD PROTECTION	YES
SHORT CIRCUIT PROTECTION	YES
OVER VOLTAGE PROTECTION	YES
WORKING TEMP	-25°C TO +50°C
DRIVER POWER	150W
RECOMMENDED MAX. LOAD	120W
IP RATING	IP66
WARRANTY	5 YEARS REPLACEMENT

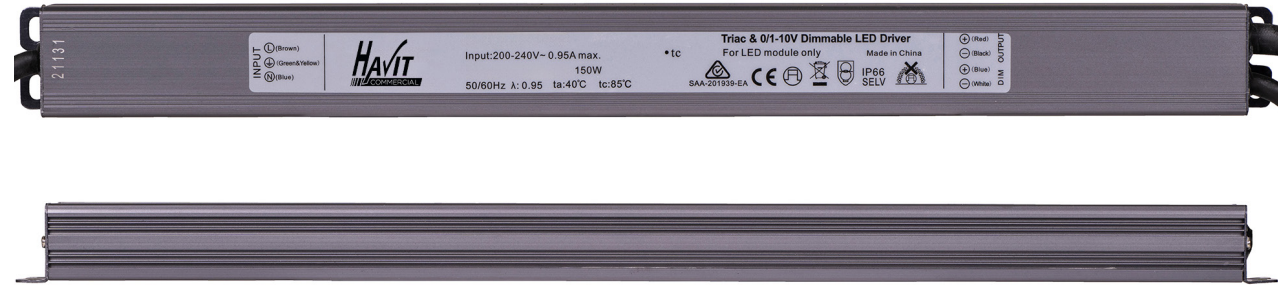

WIRING DIAGRAM

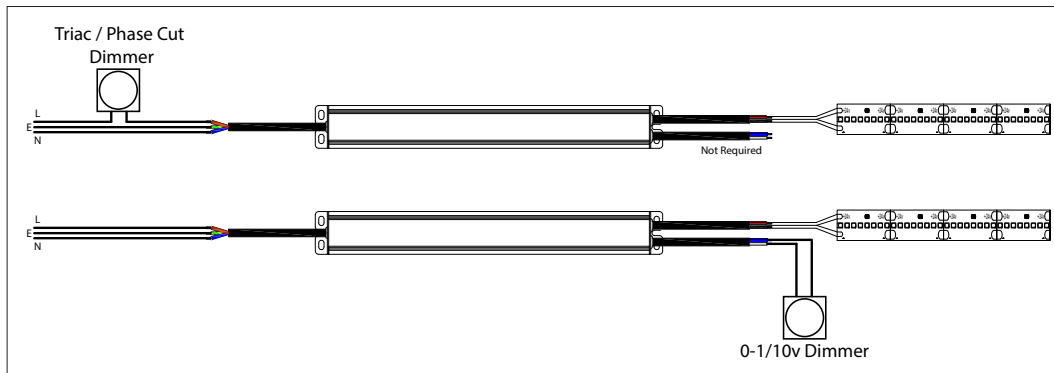

DIMENSIONS

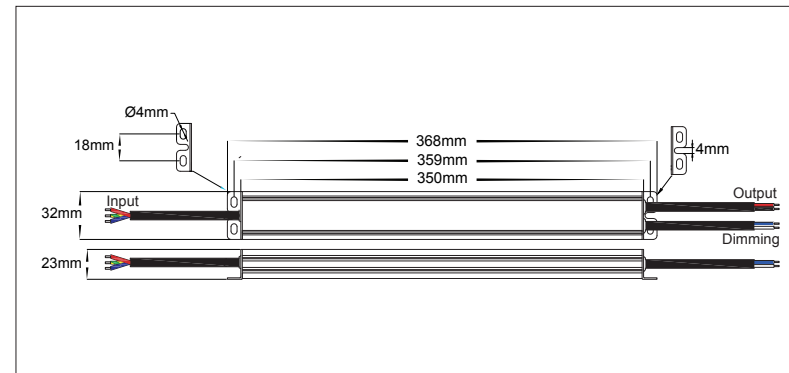

24V DC 150W TRIAC + 0-1/10V DIMMABLE LED DRIVER

Web: www.havitcommercial.com.au
Email: sales@havitcommercial.com.au
Phone: 02 9381 8383

ADDRESS: 8/133 Beauchamp Road, Matraville, N.S.W., 2036



Warranty T & Cs



Website



DRIVER TECHNICAL INFORMATION

OUTPUT	DC VOLTAGE	24V
	RATED CURRENT	6.25A
	RATED POWER	150W
	VOLTAGE TOLERANCE	±0.5V
	LOAD REGULATION	±1%
INPUT	VOLTAGE RANGE	200-240V AC
	FREQUENCY RANGE	47-63hz
	POWER FACTOR (TYP.)	0.97
	THD(Typ.) @ FULL LOAD	<20%
	EFFICIENCY (TYP.)	83%
	AC CURRENT	0.95A/230V AC
	INRUSH CURRENT	50A, 50%, 176US
PROTECTION	LEAKAGE CURRENT	<0.5mA/240V AC
	OVERLOAD	<120%, SHUT DOWN O/P VOLTAGE, REPOWER ON TO RECOVER AFTER FAULT IS REMOVED
	SHORT CIRCUIT	SHUT DOWN O/P VOLTAGE, REPOWER ON TO RECOVER AFTER FAULT IS REMOVED
	OVER TEMPERATURE	100° ± 10°
ENVIRONMENT	PROTECTION CLASS	1
	WORKING TEMPERATURE	TA: -25°C - +60°C
	WORKING HUMIDITY	20%-90%RH, NON CONDESNING
	STORAGE TEMP. & HUMIDITY	-25°C - +80°C / 10% - 95%RH
	TEMP. COEFFICIENT	±0.03%/°C (0-50°C)
SAFETY & EMC	VIBRATION	10-500Hz, 2G 12MIN./ 1 CYCLE, PERIOD FOR 72MIN. EACH ALONG X, Y, Z AXES
	SAFETY STANDARDS	COMPLIANCE TO EN61347-1, EN61347-2-13, AS/NZS61347-1 IP66 WATERPROOF RATING
	WITHSTAND VOLTAGE	I/P-O/P, I/P-FG, O/P-FG: 100Mohms/500Vdc 25°C/70%RH
	INSULATION RESISTANCE	I/P-O/P I/P-FG O/P-FG:100MΩ/500VDC/25°C/70%RH
	EMC EMISSION	COMPLIANCE TO AS/NZS CISPR15
	EMC IMMUNITY	COMPLIANCE TO AS/NZS CISPR15

