

# 1.5w Deck or Inground Light Installation Instructions



## Product Specifications

Model No.	HCP-271120	HCP-272120	HCP-276120	HCP-271220	HCP-272220	HCP-276220	HCP-274120	HCP-272420	HCP-276420
Material	316 Stainless Steel	316 Stainless Steel	Solid Brass	316 Stainless Steel	316 Stainless Steel	Solid Brass	316 Stainless Steel	316 Stainless Steel	Solid Brass
Colour	Stainless Steel	Black	Antique Brass	Stainless Steel	Black	Antique Brass	Stainless Steel	Black	Antique Brass
Cut Out	15mm to 40mm			15mm to 40mm			15mm to 40mm		
Installation Type	Ground - Recessed			Ground - Recessed			Ground - Recessed		
Trafficable	Up to 500kgs			Up to 500kgs			Up to 500kgs		
IP Rating	IP65			IP65			IP65		
IK Rating	IK10			IK10			IK10		
Input Voltage	24v DC - Requires external LED Driver			24v DC - Requires external LED Driver			24v DC - Requires external LED Driver		
Protection Class	3 (no earth required) ⚡			3 (no earth required) ⚡			3 (no earth required) ⚡		
Lamp Base	Built in LED			Built in LED			Built in LED		
Lamp Wattage	1x 1.5w			1x 1.5w			1x 1.5w		
Colour Temp	Tri Colour - 3000k, 4000k 5500k			Tri Colour - 3000k, 4000k 5500k			Tri Colour - 3000k, 4000k 5500k		
Lumens	80lm, 90lm, 85lm			2x 60lm, 2x 65lm, 2x 70lm			4x 30lm, 4x 35lm, 4x 35lm		
CRI	80+			80+			80+		
Dimmable	No			No			No		
Warranty	5 Years Replacement*			5 Years Replacement*			5 Years Replacement*		

## Dimensions

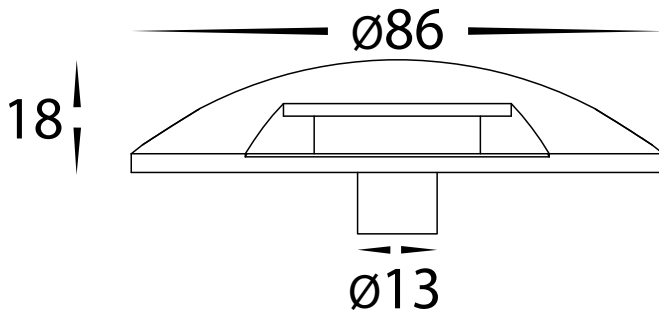

## Wiring Diagram

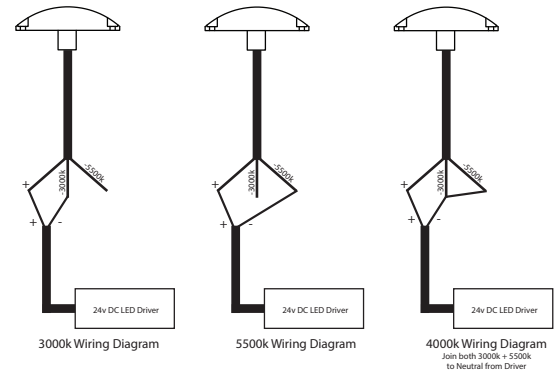

## Important Safety Issues:

- This product must be installed by a qualified electrician according to AS/NZS 3000.
- Ensure all electrical mains are disconnected before any installation. Modification of this product will void any warranty.
- Havit Commercial does not take responsibility for wrong installation, incorrect use, or use of installation material that does not belong to the system.
- All electrical connections must be watertight, If a watertight connection is not done, Warranty will be voided.
- When installing low voltage fittings, Voltage to fitting must be within +or- 5% of voltage required and cannot be installed more than 25m from LED Driver, if not within this allowance warranty will be voided.
- All o-rings and seals must be in place correctly to maintain warranty.
- These instructions may be updated at any time due to product improvements, Please visit website for most current installation instructions.

## Steps for Installation:

1. Make sure that the electrical circuit is free of voltage (master switch off)
2. Make hole in desired location using measurements above in table.
3. Insert cables through hole ready for connection.
4. Connect the cable -
5. Use an appropriate 24v DC LED Driver - DO NOT CONNECT LIGHT FITTING DIRECT TO 240V
6. Strip back the cable on both fitting and cable run and twist the positive cables together.
7. Then connect neutral cables together, Neutral cables are marked for selection of colour temperature. If 3000k or 5500k is selected you must terminate extra cable to be IP Rated to avoid any water making contact with internal parts of cable. To get 4000k, Join both 3000k + 5500k together and connect to neutral on cable run.
8. Solder all joins using solder with either a heat gun or butane gas torch.
9. Cover connections using an adhesive lined heat shrink or gel cap to make connection watertight. (failure to do this step will void warranty)
10. Push connected cables into hole and place cover over led panel.
11. Mark holes where they need to be installed and remove cover.
12. Drill holes to the dimension of wall plugs provided if being installed into brick or concrete, If installing into timber, Pre-drill small hole to make attaching screws easier.
13. Place cover over led panel and attach screws and tighten.
14. Apply silicon around edge of fitting to prevent any water from getting inside to electrical connections.
15. All connections must be carried out carefully, inspect all contacts before switching back on the electric circuit.

**Must be installed by a licensed electrician**

## Contact Details:

8/133 Beauchamp Road  
Matraville NSW 2036  
Australia  
Tel: 02 9381 8383  
Email: sales@havitcommercial.com.au  
Web: www.havitcommercial.com.au

## Warranty Terms & Conditions\*



[www.havitcommercial.com.au](http://www.havitcommercial.com.au)

