

9W 24V DC ROUND 316 STAINLESS STEEL SLIM INGROUND LIGHT

Web: www.havitcommercial.com.au
Email: sales@havitcommercial.com.au
Phone: 02 9381 8383

ADDRESS: 8/133 Beauchamp Road, Matraville, N.S.W., 2036



Warranty T & Cs



Website



PRODUCT SPECIFICATIONS	
MATERIAL	316 STAINLESS STEEL
COLOUR / FINISH	STAINLESS STEEL
COLOUR TEMP	3000K 4000K 5500K (TRI-COLOUR)
LUMENS	655LM 795LM 735LM
INPUT VOLTAGE	24V DC
PROTECTION CLASS	3 (NO EARTH REQUIRED)
LAMP BASE	BUILT IN 9W LED
DIMMING	NON-DIMMABLE
BEAM ANGLE	60°
UGR	<25
SDCM	<6
CRI	RA >80
LAMP EXPECTANCY	>30000HRS*
IK RATING	IK10
IP RATING	IP68
TRAFFICABLE	1000KG
FACE DIAMETER	Ø170MM
(CUT OUT) WITH CANISTER	Ø147MM
(CUT OUT) WITHOUT CANISTER	Ø140MM
WARRANTY	5 YEARS REPLACEMENT*

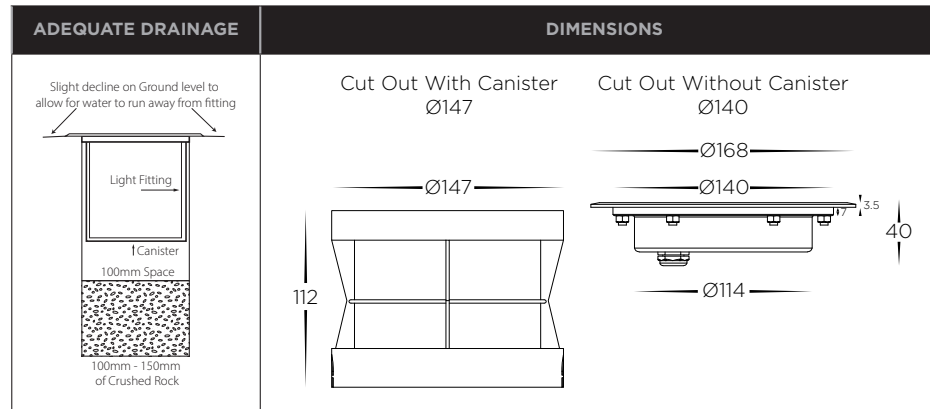

PRODUCT ORDERING

316 STAINLESS STEEL		
HCP-251092	3000K 4000K 5500K	655LM 795LM 735LM

OPTIONAL HAVIT COMPATIBLE ACCESSORIES

IMAGE	PART NUMBER	DESCRIPTION
	24v DC LED Drivers	SEE CATALOGUE OR WEBSITE FOR FULL RANGE OF 24V DC LED DRIVERS

*SEE WARRANTY TERMS & CONDITIONS FOR MORE INFORMATION

3000K

4000K

5500K