

Cono Installation Instructions

HV3651T-BLK

HV3651T-WHT

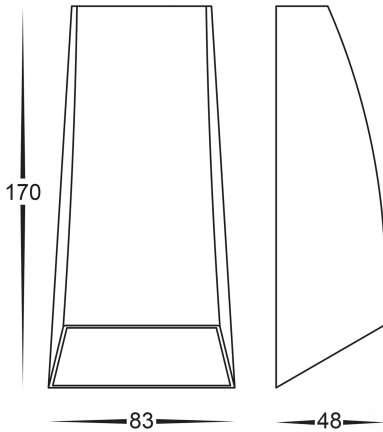

Important Safety Issues;

- This product must be installed by a qualified electrician according to AS/NZS 3000.
- Ensure all electrical mains are disconnected before any installation.
- Modification of this product will void any warranty.
- Do not touch the lamp with bare hands, and ensure to let lamp cool after use before touching. This lamp can get extremely hot.
- Havit Lighting does not take responsibility for wrong installation, incorrect use, or use of installation material that does not belong to the system.
- When installing low voltage fittings, Voltage to fitting must be within - 5% of voltage required, if not within this allowance warranty will be voided.
- Aluminum and 304SS fittings must not be installed within 2km of any salt water environments.
- When installing copper fittings, gloves must be worn to avoid any oils transferring to fitting.
- All 316 stainless steel fittings must have regular cleaning maintenance to avoid any tea staining from forming on fitting. (Warranty does not cover Tea Staining)
- When installing Constant Voltage LED Drivers, Total wattage load must not exceed 70% of driver capacity to allow for start up current of the LED fittings.
- A low voltage garden cable must be used when installing any low voltage lighting. Size of cable used must be a minimum 2.5mm but will vary depending on length of run and total load.
- All lights classed as ingrounds must have adequate drainage when installed, warranty will be voided if not installed correctly.
- All o-rings and seals must be in place correctly to maintain warranty.

Steps for Installation;

1. Make sure that the electrical circuit is free of voltage (master switch off)
2. Undo allen screws from side of fitting until baseplate can be removed.
3. Install base plate in desired location using appropriate screws for application.
4. Connect the cable -
 - 240v models, (use wire with earth); connect the earth first, then live and neutral wire.
5. Select colour temperature with switch in base plate. (Fitting is set to 3000k from factory)
6. Reattach fitting to baseplate and tighten allen screws making sure its tight to avoid water penetration.
7. Apply silicon around fitting to avoid water penetration. Failure to do so will void warranty.
8. All connections must be carried out carefully, inspect all contacts before switching back on the electric circuit.

THESE FITTINGS MUST BE INSTALLED BY A LICENSED ELECTRICIAN