

## **PRODUCT SPECIFICATIONS**

**Name:** Seevive

**Material:** Polycarb

**Colour:** Black or White

**IP Rating:** IP65

**Lamp Base:** Built in LED

**CRI:** ≥80

**Wiring:** Parallel

**Dimmable:** No

**Warranty:** 2 years replacement\*\*

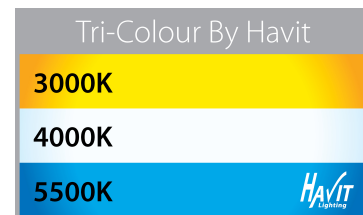
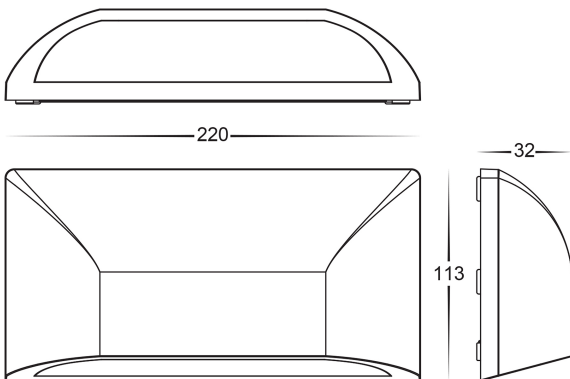

PART NUMBER	COLOUR TEMP	LUMENS*	INPUT VOLTAGE	BEAM ANGLE	INCLUDED GLOBES
HV3225T-WHT	3000k	150lm	12v DC	120°	Built in 5w LED
HV3225T-BLK	4000k	155lm			
	5500k	160lm			

\* Lumen output measured at source

\*\* See Warranty Terms and Conditions for more information