

Seefore Step Light Installation Instructions



Product Specifications

Model No.	HV3222T-BLK	HV3222T-WHT
Name	Seefore	
Material	Polycarbonate	
Colour	Black	White
IP Rating	IP65	
Input Voltage	12v DC	
Lamp Base	Built in LED	
Lamp Wattage	3w	
Colour Temp	TRI Colour - 3000k, 4000k, 5500k	
Lumens	90lm, 95lm, 100lm	
CRI	> 80	
Wiring	Parallel	
Dimmable	No	
Warranty	2 Years Replacement*	

Dimensions

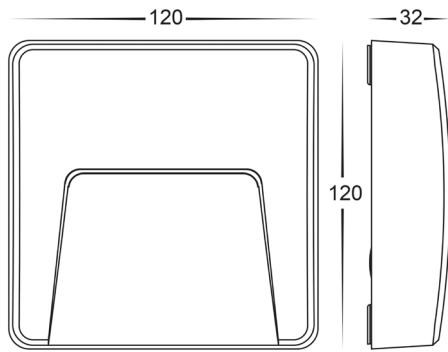

Mounting Base Diagram

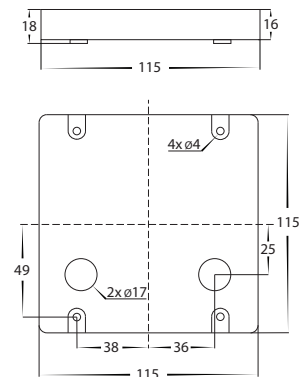

Important Safety Issues:

- This product must be installed by a qualified electrician according to AS/NZS 3000.
- Ensure all electrical mains are disconnected before any installation.
- Do not exceed maximum wattage restrictions for globes: 240V GU10 = 35w / 12V MR16 = 20w
- Modification of this product will void any warranty.
- Havit Lighting does not take responsibility for wrong installation, incorrect use, or use of installation material that does not belong to the system.
- When installing low voltage fittings, Voltage to fitting must be within +or- 5% of voltage required and cannot be installed more than 25m from LED Driver, if not within this allowance warranty will be voided.
- Aluminium and 304SS fittings must not be installed within 2km of any salt water environments.
- When installing copper fittings, gloves must be worn to avoid any oils transferring to fitting.
- All 316 stainless steel fittings must have regular cleaning maintenance to avoid any tea staining from forming on fitting. (Warranty does not cover Tea Staining)
- All o-rings and seals must be in place correctly to maintain warranty.
- These instructions may be updated at any time due to product improvements, Please visit website for most current installation instructions.

Steps for Installation:

1. Make sure that the electrical circuit is free of voltage (master switch off)
2. Remove face from base plate
3. Remove screws and clear cover from front of fitting as set aside.
4. Install base plate in desired location
5. Using an appropriate 12v LED Driver - DO NOT CONNECT LIGHT FITTING DIRECTLY TO 240V
6. Connect the cable - If more than one fitting installed, wiring must be done in parallel.
7. Fitting is preset to 3000k, To change move switch above PCB to desired colour temperature
8. Reattach clear cover making sure screws are tight to avoid water penetration.
9. Reattach face onto fitting.
10. Apply silicon around edge of fitting to prevent any water from getting inside to electrical connections.
11. All connections must be carried out carefully, inspect all contacts before switching back on the electric circuit.

Must be installed by a licensed electrician

Contact Details:

143 Beauchamp Road
Matraville NSW 2036
Australia
Tel: 02 9381 8300
Fax: 02 9666 8881
Email: sales@havit.com.au
Web: www.havit.com.au

Warranty Terms & Conditions*



Additional Information



HV3222T-BLK



HV3222T-WHT