

Pinta Step Light Installation Instructions



Product Specifications

Model No.	HV2902	HV2902-AB	HV2904T	HV2904T-AB	HV2905T-12V
Name	Pinta				
Material	316 Stainless Steel	Brass	316 Stainless Steel	Brass	316 Stainless Steel
Colour	Stainless Steel	Antique Brass	Stainless Steel	Antique Brass	Stainless Steel
IP Rating	IP65				
Input Voltage	12v		12v DC		
Lamp Base	G4		Built in LED		
Lamp Wattage	Max 20w	Max 20w	2.3w		
Colour Temp	N/A	N/A	TRI Colour - 3000k, 4000k, 5500k		
Lumens	N/A	N/A	160lm, 170lm, 180lm		
CRI	> 80				
Wiring	Parallel				
Dimmable	No				
Warranty	2 Years Replacement*				

Dimensions

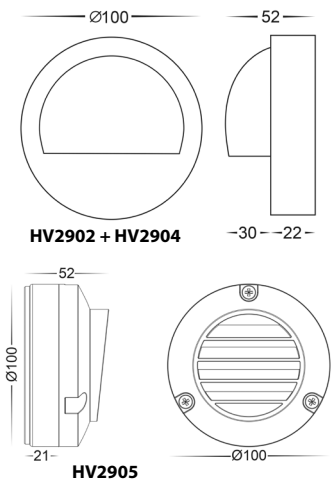

Important Safety Issues:

- This product must be installed by a qualified electrician according to AS/NZS 3000.
- Ensure all electrical mains are disconnected before any installation.
- Do not exceed maximum wattage restrictions for globes: 240V GU10 = 35w / 12V MR16 = 20w
- Modification of this product will void any warranty.
- Havit Lighting does not take responsibility for wrong installation, incorrect use, or use of installation material that does not belong to the system.
- When installing low voltage fittings, Voltage to fitting must be within +or- 5% of voltage required and cannot be installed more than 25m from LED Driver, if not within this allowance warranty will be voided.
- Aluminium and 304SS fittings must not be installed within 2km of any salt water environments.
- When installing copper fittings, gloves must be worn to avoid any oils transferring to fitting.
- All 316 stainless steel fittings must have regular cleaning maintenance to avoid any tea staining from forming on fitting. (Warranty does not cover Tea Staining)
- All o-rings and seals must be in place correctly to maintain warranty.
- These instructions may be updated at any time due to product improvements, Please visit website for most current installation instructions.

Mounting Base Diagram

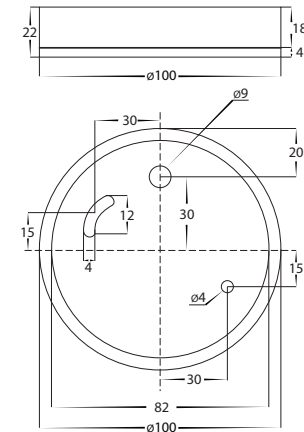

Steps for Installation for HV2902 Models:

- Make sure that the electrical circuit is free of voltage (master switch off)
- Remove screws from front of fitting as set aside.
- Install base plate in desired location
- Using an appropriate 12v LED Driver or transformer - DO NOT CONNECT LIGHT FITTING DIRECTLY TO 240V
- Connect the cable into terminal block - Positive from cable run to positive of fitting then connect the neutral - If more than one fitting installed, wiring must be done in parallel.
- Insert globe into fitting making sure globe can be used with selected driver.
- Reattach face onto fitting making sure seals are still in place and screws are tight to avoid water penetration into fitting
- Apply silicon around edge of fitting to prevent any water from getting inside to electrical connections.
- All connections must be carried out carefully, inspect all contacts before switching back on the electric circuit.

Steps for Installation for HV2904 + HV2905 Models:

- Make sure that the electrical circuit is free of voltage (master switch off)
- Remove screws from front of fitting as set aside.
- Using an appropriate 12v LED Driver - DO NOT CONNECT LIGHT FITTING DIRECTLY TO 240V
- Connect the cable - If more than one fitting installed, wiring must be done in parallel.
- Strip back the cable on both fitting and cable run and twist the positive cables together. Then connect neutral cables together
- Solder all joins using solder and either a heat gun or butane gas torch.
- Cover connections using an adhesive lined heat shrink or gel cap to make connection watertight. Failure to do this will void warranty.
- Heat the heat shrink or crimp the gel cap making sure all connections are covered.
- Install base plate in desired location
- Fitting is preset to 3000k, To change move switch above PCB to desired colour temperature
- Reattach face onto fitting making sure seals are still in place and screws are tight to avoid water penetration into fitting
- Apply silicon around edge of fitting to prevent any water from getting inside to electrical connections.
- All connections must be carried out carefully, inspect all contacts before switching back on the electric circuit.

Must be installed by a licensed electrician

Contact Details:

143 Beauchamp Road
Matrville NSW 2036
Australia
Tel: 02 9381 8300
Fax: 02 9666 8881
Email: sales@havit.com.au
Web: www.havit.com.au

Warranty Terms & Conditions*



Additional Information

