

Highlite Bollard Light Installation Instructions

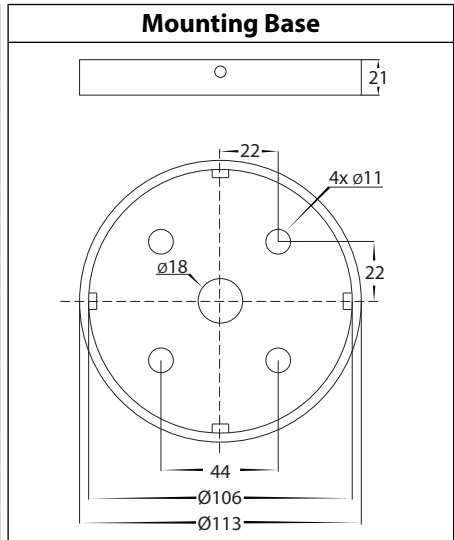

Product Specifications		
Model No.	HV1625T-BLK-240V	HV1626T-BLK-240V
Name	Highlite	
Material	Aluminium	
Colour	Black	
IP Rating	IP65	
Input Voltage	240v AC	
Lamp Base	Built in LED	
Lamp Wattage	1x 24w (optional selection for 18w)	
Colour Temp	TRI Colour - 3000k, 4000k, 5500k	
Lumens	1900lm, 1970lm, 2040lm	
CRI	> 80	
Wiring	Parallel	
Dimmable	No	
Warranty	2 Years Replacement*	



Important Safety Issues:

- This product must be installed by a qualified electrician according to AS/NZS 3000.
- Ensure all electrical mains are disconnected before any installation.
- Modification of this product will void any warranty.
- Havit Lighting does not take responsibility for wrong installation, incorrect use, or use of installation material that does not belong to the system.
- When installing low voltage fittings, Voltage to fitting must be within +or- 5% of voltage required, if not within this allowance warranty will be voided.
- Aluminium and 304SS fittings must not be installed within 2km of any salt water environments.
- When installing copper fittings, gloves must be worn to avoid any oils transferring to fitting.
- All 316 & 304 stainless steel fittings must have regular cleaning maintenance to avoid any tea staining from forming on fitting. (Warranty does not cover Tea Staining)
- All o-rings and seals must be in place correctly to maintain warranty
- When installing surface mounted bollards, base plate must be installed on concrete or concrete pad, Fitting should not be installed under ground level, all holes including cable entry must be siliconed to prevent any water penetration into fitting, silicon must also be applied around fitting at ground level. Failure to do this will void warranty
- This form may be updated at any time due to product improvements, please check online installation form for most current version.

Dimensions

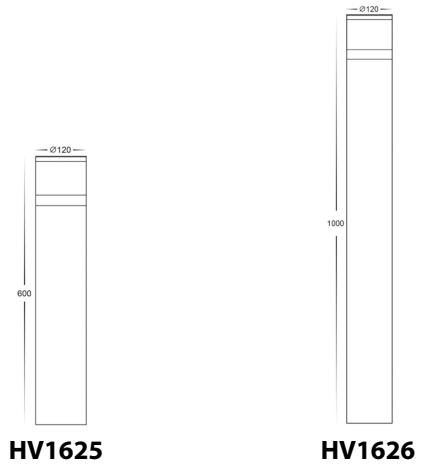

Steps for Installation:

1. Make sure that the electrical circuit is free of voltage (master switch off).
2. Remove 4x allen screws from side of fitting and put aside
3. Install baseplate in desired location using appropriate screws for application. The screws supplied are mild steel which must be replaced with higher grade if there is any chance of them being affected by water. The location of baseplate must be installed on either concrete or concrete base and cannot be installed under ground level.
4. Locate IP rated junction box within fitting. Undo screws from junction box and remove cover.
5. Insert cable through cable gland on junction box. If your cable is not circular you must fix entry of your cable to maintain IP rating. Failure to do so will void warranty.
6. Connect the cable using wire with earth. Connect earth first, then live and neutral wires.
7. Reattach cover to IP rated junction box making sure screws are tight and seals are still in place.
8. Silicon all cable entry holes and fixing points on baseplate to avoid moisture penetration into fitting.
9. Place bollard onto base plate and reattach 4x allen screws set aside earlier
10. Colour temperature is set to 3000k and 24w. To change, Remove cover from fitting by twisting anti clockwise. Select desired colour temperature or wattage by moving switch located in centre of PCB
11. Reattach cover by turning clockwise making sure the seals are still in place and cover is tight to avoid any water penetration.
12. All connections must be carried out carefully, inspect all contacts before switching back on the electric circuit.

Must be installed by a licensed electrician

Contact Details:

143 Beauchamp Road
 Matraville NSW 2036
 Australia
 Tel: 02 9381 8300
 Fax: 02 9666 8881
 Email: sales@havit.com.au
 Web: www.havit.com.au

Warranty Terms & Conditions*



Additional Information



HV1625T-BLK-240V



HV1626T-BLK-240V