

# Spitze Single Adjustable Garden Spike Light Installation Instructions



## Product Specifications

Model No.	HV1428W	1428N	HV1428C
Name	Spitze		
Material	Aluminium		
Colour	Black		
IP Rating	IP65		
Input Voltage	12v DC		
Lamp Base	Built in LED		
Lamp Wattage	1x 3w		
Colour Temp	3000k	4000k	5500k
Lumens	270lm	285lm	300lm
CRI	> 80		
Wiring	Parallel		
Dimmable	No		
Warranty	2 Years Replacement*		

## Important Safety Issues:

- This product must be installed by a qualified electrician according to AS/ NZS 3000.
- Ensure all electrical mains are disconnected before any installation.
- Do not exceed maximum wattage restrictions for globes: 240V GU10 = 35w / 12V MR16 = 20w
- Modification of this product will void any warranty.
- Havit Lighting does not take responsibility for wrong installation, incorrect use, or use of installation material that does not belong to the system.
- When installing low voltage fittings, Voltage to fitting must be within +or- 5% of voltage required and cannot be installed more than 25m from LED Driver, if not within this allowance warranty will be voided.
- Aluminium and 304SS fittings must not be installed within 2km of any salt water environments.
- When installing copper fittings, gloves must be worn to avoid any oils transferring to fitting.
- All 316 stainless steel fittings must have regular cleaning maintenance to avoid any tea staining from forming on fitting. (Warranty does not cover Tea Staining)
- All o-rings and seals must be in place correctly to maintain warranty.
- These instructions may be updated at any time due to product improvements, Please visit website for most current installation instructions.

## Sample Wiring Diagram

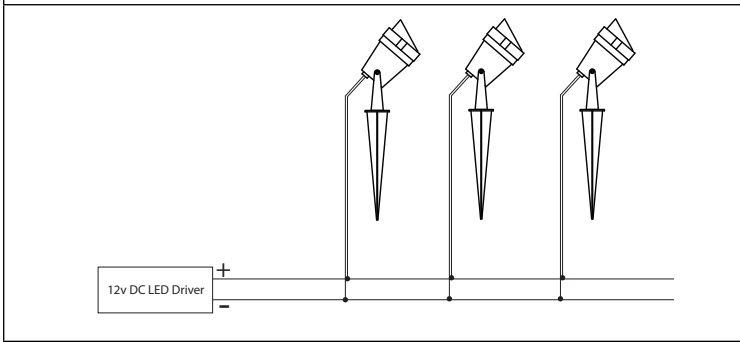

## Dimensions

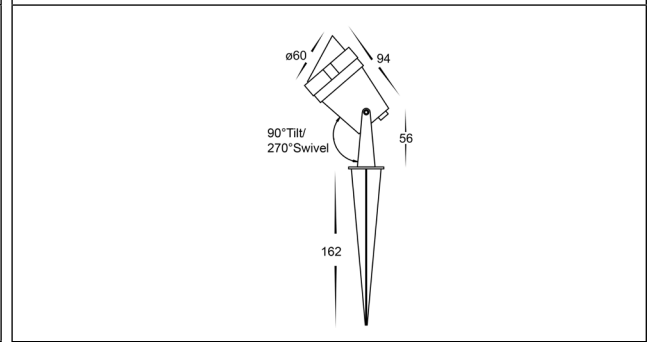

## Steps for Installation:

1. Make sure that the electrical circuit is free of voltage (master switch off)
2. Place fitting in desired location
3. Connect the cable -
4. Use an appropriate 12v DC LED Driver - DO NOT CONNECT LIGHT FITTING DIRECT TO 240V
5. Strip back cable on both fittings and cable run and twist the positive cable from fitting to positive on the cable run, then connect neutral from fitting to neutral on the cable run.
6. Solder all joins using solder with either a heat gun or butane gas torch.
7. Cover connections using an adhesive lined heat shrink or gel cap to make connection watertight. (failure to do this step will void warranty)
8. Heat the heat shrink or crimp the gel cap making sure all connections are covered.
9. Adjust fitting to desired position making sure to stop rotating when fitting cannot rotate anymore, If forced fitting will continue to rotate and cause internal cables to become entangled causing fitting to short. If this is done, warranty will be voided.
10. All connections must be carried out carefully, inspect all contacts before switching back on the electric circuit.

**Must be installed by a licensed electrician**

### Contact Details:

143 Beauchamp Road Tel: 02 9381 8300  
 Matraville NSW 2036 Fax: 02 9666 8881  
 Australia Email: sales@havit.com.au  
 Web: www.havit.com.au

### Warranty Terms & Conditions\*



### Additional Information

