

Maxi Tivah Fixed Down Wall Light Installation Instructions



Product Specifications

Model No.	HV1108T	HV1128T
Name	Tivah	
Material	316 Stainless Steel	Aluminium
Colour	Stainless Steel	Black
IP Rating	IP65	
Input Voltage	240v AC	
Lamp Base	Built in LED	
Lamp Wattage	1x 12w	
Lumens	1080lm, 1140lm, 1200lm	
Colour Temp	TRI Colour - 3000k, 4000k, 5500k	
CRI	> 80	
Wiring	Parallel	
Dimmable	No	
Warranty	2 Years Replacement*	

Important Safety Issues:

- This product must be installed by a qualified electrician according to AS/NZS 3000.
- Ensure all electrical mains are disconnected before any installation.
- Do not exceed maximum wattage restrictions for globes:
240V GU10 = 35w / 12V MR16 = 20w
- Modification of this product will void any warranty.
- Havit Lighting does not take responsibility for wrong installation, incorrect use, or use of installation material that does not belong to the system.
- When installing low voltage fittings, Voltage to fitting must be within +or- 5% of voltage required, if not within this allowance warranty will be voided.
- Aluminium and 304SS fittings must not be installed within 2km of any salt water environments.
- When installing copper fittings, gloves must be worn to avoid any oils transferring to fitting.
- All 316 stainless steel fittings must have regular cleaning maintenance to avoid any tea staining from forming on fitting.
(Warranty does not cover Tea Staining)
- All o-rings and seals must be in place correctly to maintain warranty.
- These instructions may be updated at any time due to product improvements, Please visit website for most current installation instructions.

Mounting Bracket + Dimensions

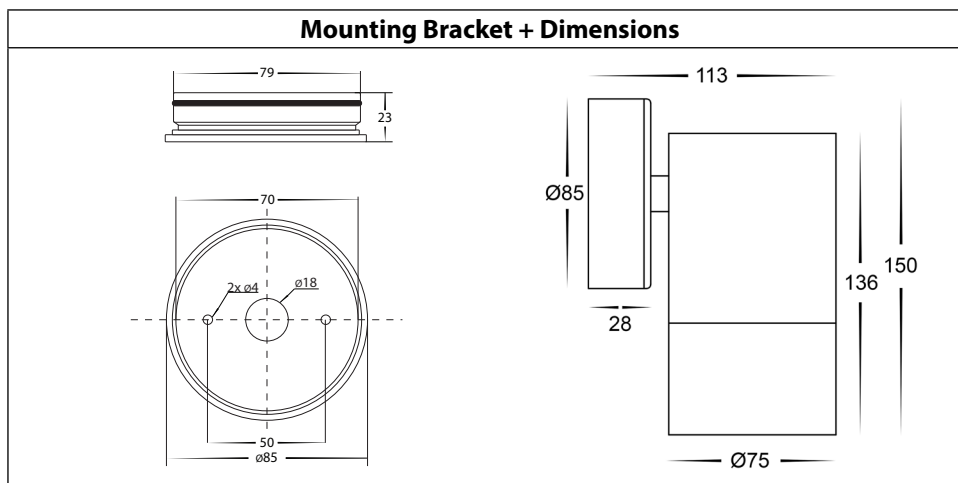

Steps for Installation:

1. Make sure that the electrical circuit is free of voltage (master switch off)
2. Loosen allen screws on side of base and separate mounting bracket from fitting.
3. Install the backing plate securely using appropriate screws for application, Seal all holes in the backing plate including cable entry and screw holes. Failure to do so will void warranty.
4. Connect the cable - use wire with earth; connect the earth first, then live and neutral wire
5. Affix the fitting to the mounting bracket and tighten screws, making sure these are tight to avoid any water penetration.
6. Apply silicon seal around the whole base plate to avoid any water getting into electrical connections.
7. Colour temperature is preset to 3000k, to change remove covers from fitting by twisting anti clockwise and set aside. Move switch and select desired colour temperature.
8. Reattach covers by turning clockwise making sure the seals are still in place and caps are tight to avoid any water penetration.
9. All connections must be carried out carefully, inspect all contacts before switching back on the electric circuit.

Must be installed by a licensed electrician

Contact Details:

143 Beauchamp Road
Matraville NSW 2036
Australia

Tel: 02 9381 8300
Fax: 02 9666 8881
Email: sales@havit.com.au
Web: www.havit.com.au

Warranty Terms & Conditions*



Additional Information



HV1108T



HV1128T