

VOX SERIES

Exterior LED Surface Mounted Up/Down Wall Lights



Exterior Lighting

Product Features

- Exterior surface mounted up/down LED wall lights
- Input voltage: 100~240V AC 50/60Hz
- Output voltage: 5.5~30V
- Nominal current: 350mA
- Material: aluminium
- Bracket: aluminium
- LED chips: 32pcs SMD2835 LED chips
- Wattage: 9W
- Power factor: ≥ 0.5
- Ambient temp: -20 to $+45^{\circ}\text{C}$
- Not suitable for dimming
- Suitable for 2-way switching
- Suitable for use with PIR & Microwave sensors

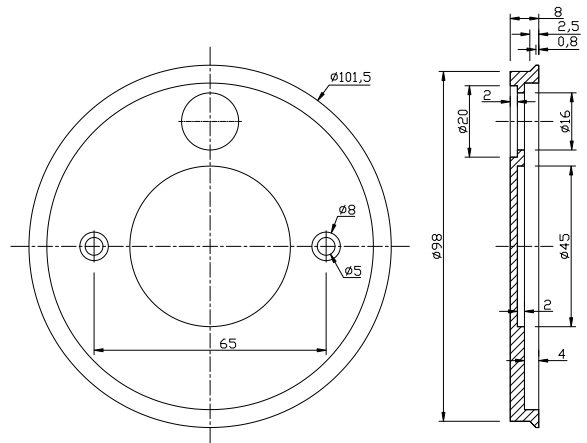
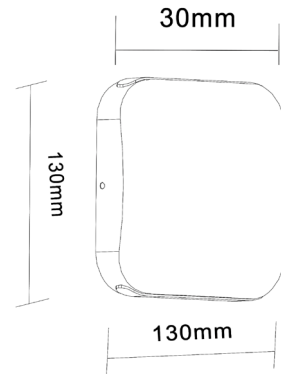

Back plate dimensions

PART NO.	DESCRIPTION	KELVIN (K)	LUMENS (LM)	WATT (W)	CRI	WIDTH (MM)	DEPTH (MM)	WEIGHT (KG)	BOX (CM)	CARTON QTY
VOX1	WALL LED S/M BLK SQ Up/Down 3000K	3000	737	9	80	130	30	0.75	15x14x4	24
VOX2	WALL LED S/M Sand WH SQ Up/Down 3000K	3000	737	9	80	130	30	0.75	15x14x4	24
VOX3	WALL LED S/M Polished Alu SQ Up/Down 3000K	3000	737	9	80	130	30	0.75	15x14x4	24

UPDATED ON 19.11.2018