

# Telbix.

## WARRANTY

TELBIX LED FIXTURES are covered by a  
\*THREE YEAR REPLACEMENT WARRANTY (domestic installations)  
TWO year replacement warranty (commercial installations)  
as stated on the terms and conditions herein.

Please also note warranty requirements will need the following details :

model number  
the production number (PO#)  
date of purchase  
place of purchase  
Copy of receipt of purchase  
Copy of Electrical contractors compliance certificate.

### WARRANTY PERIOD

The warranty only applies if the products have been installed in accordance with the installation instructions included with the product.  
The \*THREE YEAR REPLACEMENT WARRANTY applies to domestic use only, commencing from date of purchase.  
Copies of receipts of purchase and Electrical contractors compliance certificate are required.

### WARNINGS :

- This product must be installed by a licensed electrician strictly in accordance with the current revision of AS/NZS 3000.
  - Avoid touching the LEDs.
  - Please do not attempt to disassemble or change the construction of the luminaire or replace any of the parts to avoid the possibility of injury or product failure.
  - Please keep this manual for future reference.
  - This luminaire is designed for wall installation only.
  - The light source contained in this luminaire cannot be replaced.
  - Please note that the fixture is equipped with standard surge protection only.
- To protect the fixture from sags , surges , and lightning strikes, additional surge protectors must be deployed on the primary side.

# Telbix.

## CLARION EXTERIOR SECURITY FLOOD LIGHT with SENSOR

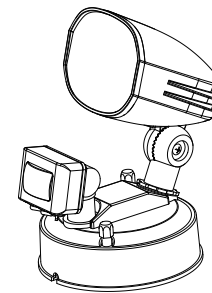

CLARION EX1S-BK

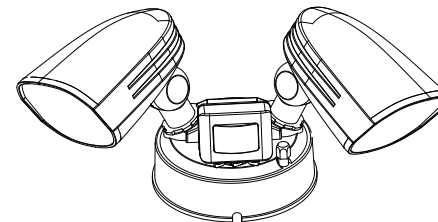

CLARION EX2S-BK



**IP54**

Email: [sales@telbix.com](mailto:sales@telbix.com)

TELBIX PTY LTD. A.B.N. 14 005 453 547

### CLARION EXTERIOR SECURITY FLOOD LIGHT with SENSOR

#### Specification

Item No.	CLARION EX1S-BK	CLARION EX2S-BK
Product Name	CLARION Single Sensor Exterior	CLARION Twin Sensor Exterior
Wattage	10W	20W
Input Voltage	220-240VAC	220-240VAC
Lumen	900lm	1800lm
CCT	3000K-4000K-6000K	3000K-4000K-6000K
IP Rating	IP54	IP54
Beam angle	90°	90°
CRI	>80	>80
Suger protection	1500V	1500V
Sensor type	PIR Sensor	PIR Sensor
Dection range	120°	120°
Detection distance	10m ±2m	10m ±2m
Time-delay	10-7min ±2min	10-7min ±2min
Light control	10-2000lux	10-2000lux
Installtion height	1.8-2.5m	1.8-2.5m
Manual override	Yes	Yes
Material	Alumimium + PC	Alumimium + PC
Product Net weight	0.34 KG	0.54 KG

#### Sensor Function

1. Can identify day and night: The consumer can adjust work ambient light. It can work in the daytime and at night when it is adjusted on the "sun" position (max). It can work in the ambient light less than 10LUX when it is adjusted on the "moon" position (min). As for the adjustment pattern, please refer to the testing pattern.
2. SENS adjustable: It can be adjusted according to using location; low sensitivity with 5m for detection distance; high sensitivity with 10m, it fits for large room.
3. To override Sensor Function, quickly switch the power off/on off/on twice at the wall switch (less than 3 seconds). Your light should now be on MANUAL MODE and stay on permanently.
4. To change back to AUTO MODE, turn the power OFF and wait for 10 seconds, then turn it back ON again. Please note that at this time the light will turn ON for 10-20 seconds and turn OFF again – at this point it will return to AUTO/SENSOR MODE.



Good sensitivity



Poor sensitivity

**Note:** when testing in daylight, please turn LUX knob to ☀ (SUN) position, otherwise the sensor lamp could not work !

### CLARION EXTERIOR SECURITY FLOOD LIGHT with SENSOR

The product is energy - saving automatic sensor lamp , adopting integrated circuit and precise detecting components .It gathers automatism ,convenience ,safety,saving-energy and practical function . Its performance is stable . It can identify day and night .The lamp can turn on when one entes detection field and can turn off automatically when one leaves detection field.

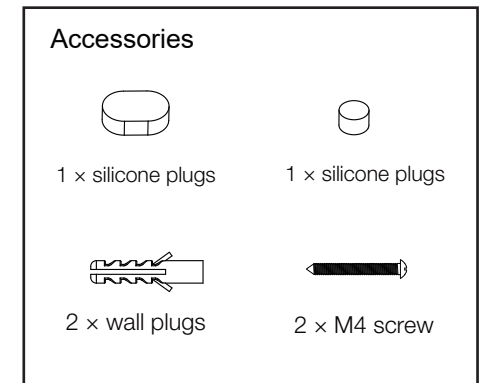
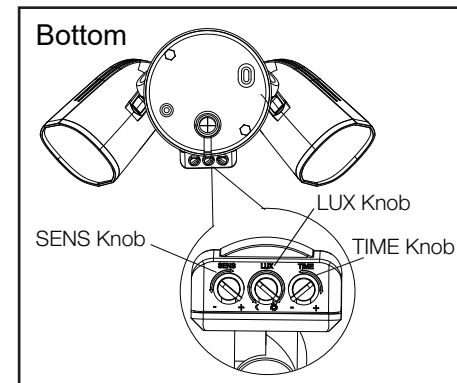
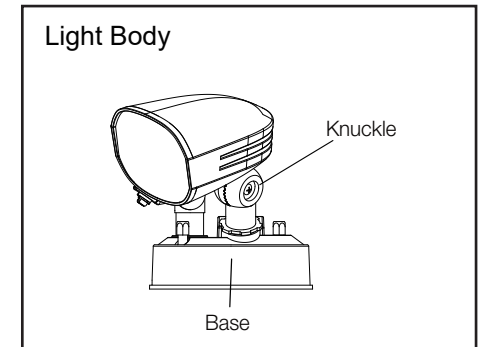
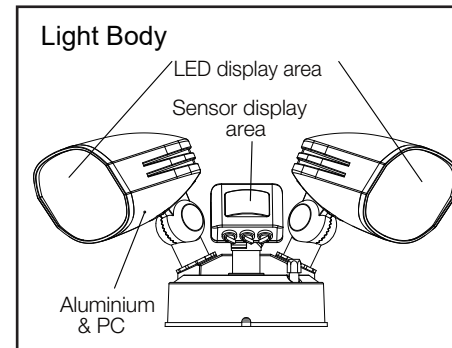

Email: sales@telbix.com

TELPIX PTY LTD. A.B.N. 14 005 453 547

## CLARION EXTERIOR SECURITY FLOOD LIGHT with SENSOR

### Description of the rotation of each part

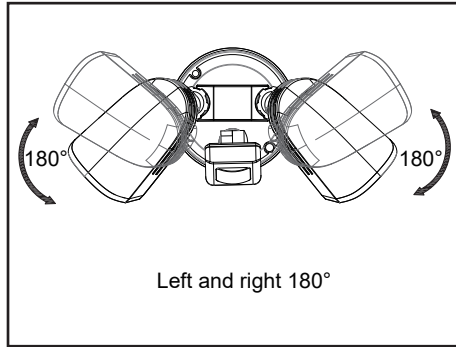
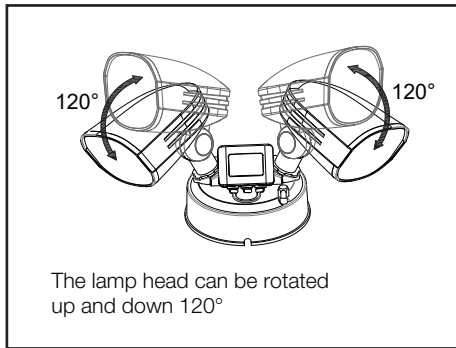

### Sensor angle

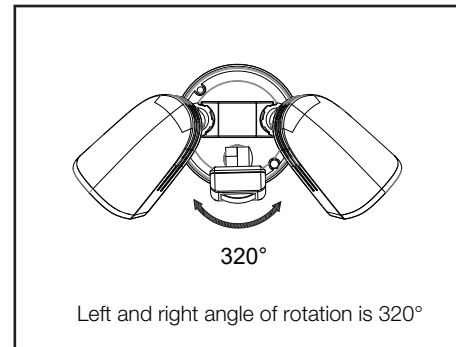
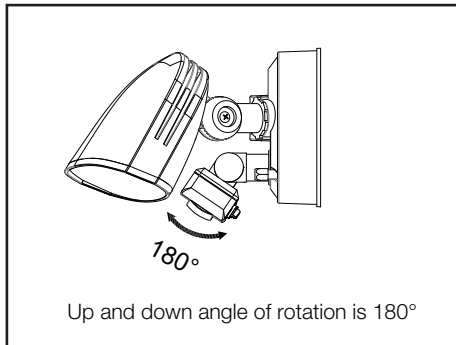

## CLARION EXTERIOR SECURITY FLOOD LIGHT with SENSOR

**NOTE :** This product must be installed by a licensed electrician .

**NOTE :** For best performance install at a height between 2 and 2.5 metres .

