

WARRANTY

TELBIX LED FIXTURES are covered by a
*THREE YEAR REPLACEMENT WARRANTY (domestic installations)
TWO year replacement warranty (commercial installations)
as stated on the terms and conditions herein.

Please also note warranty requirements will need the following details :

model number
the production number (PO#)
date of purchase
place of purchase
Copy of receipt of purchase
Copy of Electrical contractors compliance certificate.

WARRANTY PERIOD

The warranty only applies if the products have been installed in accordance with the installation instructions included with the product.
The *THREE YEAR REPLACEMENT WARRANTY applies to domestic use only, commencing from date of purchase.
Copies of receipts of purchase and Electrical contractors compliance certificate are required.

WARNINGS :

- This product must be installed by a licensed electrician strictly in accordance with the current revision of AS/NZS 3000.
 - Avoid touching the LEDs.
 - Please do not attempt to disassemble or change the construction of the luminaire or replace any of the parts to avoid the possibility of injury or product failure.
 - Please keep this manual for future reference.
 - This luminaire is designed for wall installation only.
 - The light source contained in this luminaire cannot be replaced.
 - Please note that the fixture is equipped with standard surge protection only.
- To protect the fixture from sags , surges , and lightning strikes, additional surge protectors must be deployed on the primary side.

CLARION EXTERIOR SECURITY FLOOD LIGHT

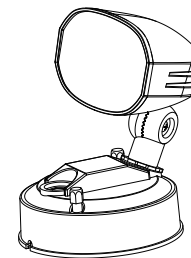

CLARION EX1-BK

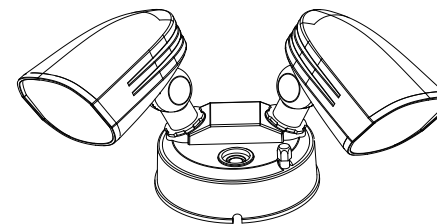

CLARION EX1-BK



IP54

Email: sales@telbix.com

TELBIX PTY LTD. A.B.N. 14 005 453 547

CLARION EXTERIOR SECURITY FLOOD LIGHT

Specification

Item No.	CLARION EX1-BK	CLARION EX2-BK
Product Name	CLARION Single Exterior	CLARION Twin Exterior
Wattage	10W	20W
Input Voltage	220-240VAC	220-240VAC
Lumen	900lm	1800lm
CCT	3000K-4000K-6000K	3000K-4000K-6000K
IP Rating	IP54	IP54
Beam angle	90°	90°
CRI	>80	>80
Suger protection	1500V	1500V
Sensor type	-	-
Dection range	-	-
Detection distance	-	-
Time-delay	-	-
Light control	-	-
Installtion height	-	-
Manual override	-	-
Material	Alumimium + PC	Alumimium + PC
Product Net weight	0.3 KG	0.50 KG

CLARION EXTERIOR SECURITY FLOOD LIGHT

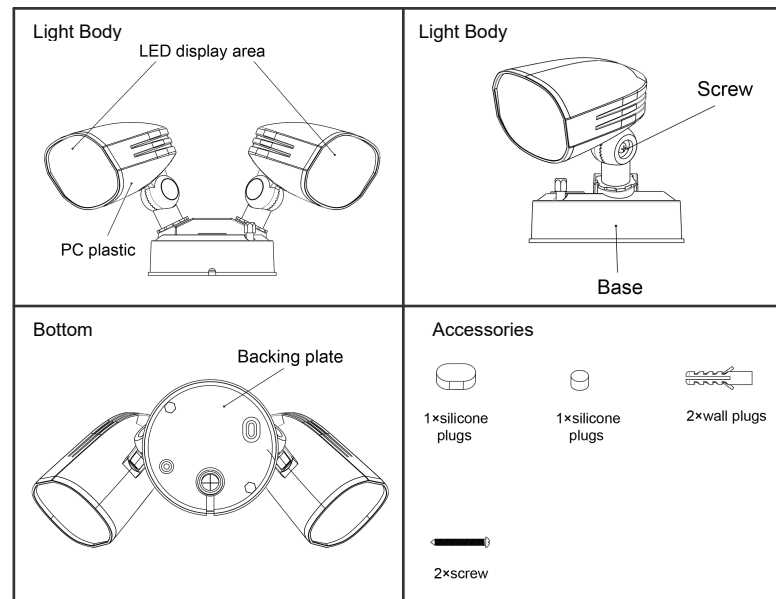

IP54

Email: sales@telbix.com

TELBIx PTy LTD. A.B.N. 14 005 453 547

CLARION EXTERIOR SECURITY FLOOD LIGHT

Description of the rotation of each part

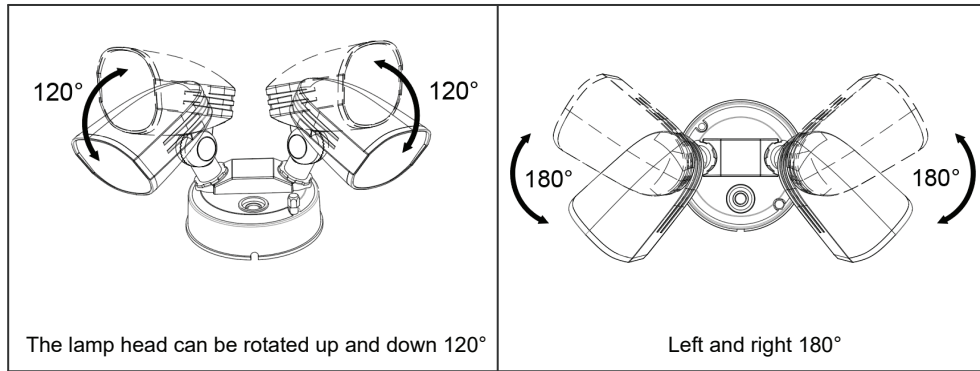

CLARION EXTERIOR SECURITY FLOOD LIGHT

NOTE : This product must be installed by a licensed electrician.

