

CARTER-PDT-SML

Specifications

Voltage:	240V	Lamp Base:	E27
Power:	25W Max	IP Rating:	IP20

- A. Timber
- B. Mounting Bracket
- C. Mounting Screws
- D. Terminal Block
- E. Canopy Screws
- F. Lamp Holder
- G. Shade
- H. Tightening Ring
- I. E27 Lamp

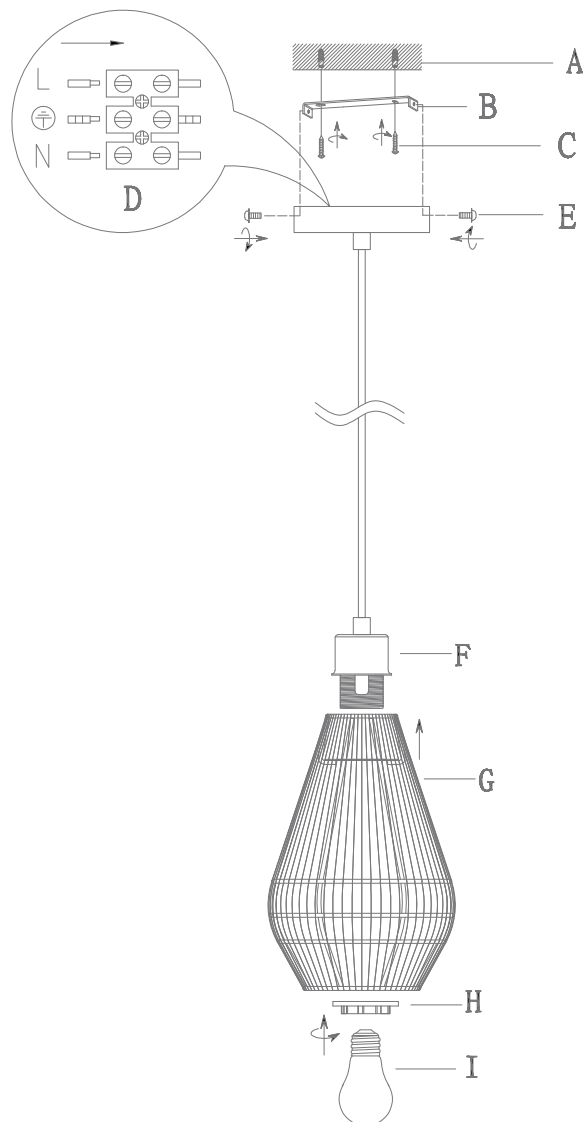

Note: -The lamp must be installed by professional electrician
 -Ensure the power supply is switched off before fitting this product

-Do not touch the lamp when in use
 -Keep away from hot steam and corrosive gas