

BOOST-10 TRIO LED Downlight



Description

The BOOST range of LED downlights has been specifically designed by incorporating cost saving materials to produce a cost effective and well performing downlight solution to the market. Bright output 10W LED recessed downlight with anti-glare deep set frame, opal diffuser, dimmable LED driver flex & plug. Fully dimmable with suitable dimmers. Now with TRIO, the added option of changing the colour temperature output of the downlight with a dip switch at the back of the fitting. The BOOST series offers the customer a range of performance features including a unique thermal management system not offered by others.

Specification Features

Input Voltage:	240V AC
Power (W):	10W
IP rating (IP):	54
Lumens (lm):	Warm White 3000K - 750lm Neutral White 4000K - 780lm White 5700K - 800lm
LED type:	SMD
CCT:	3000K - 4000K - 5700K (Switchable)
CRI:	≥83
Beam angle (°):	90°
Dimmable:	Yes*
Lifespan (hrs):	40,000hrs
Cutout (Ø):	Ø90mm

* Fully dimmable with suitable dimmers.



Diagrams / Additional

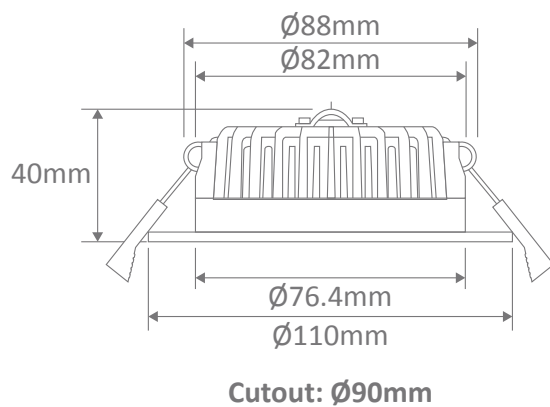

Item No.	Variant	Colour
BOOST-10-WHT	20726	TRIO
BOOST-10-BLK	20727	

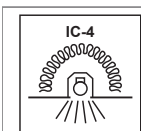
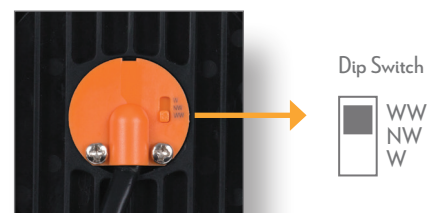

Recessed Luminaire where fixed building insulation material can abut and cover the recessed luminaire. Building insulation does not have to be non flammable. Building Insulation must maintain structural integrity at 90 degrees C.
Important: IC-4 Downlights are not to be used in the Fire Rated Applications.